

HF-ES 50 5-6

HF-cable clamp for angular profile fastening

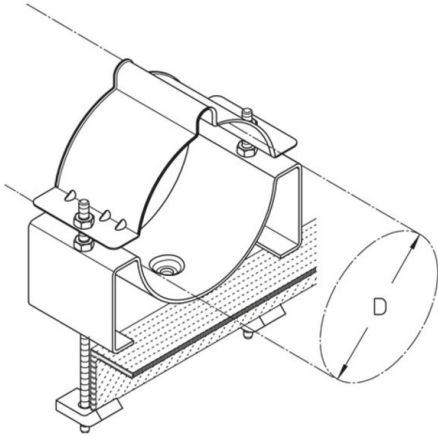

Zinc coated

Product	D	G
HF-ES 50 5	128 (E 26-30) mm	104,2 kg/100
HF-ES 50 6	160 (E 20) mm	120 kg/100

D: diameter
G: weight

DETAILS / APPLICATIONS

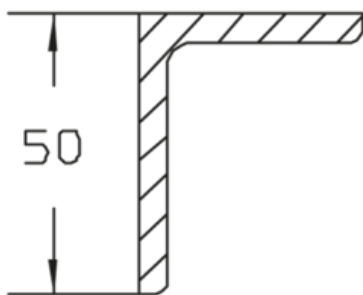



OPTIONAL ACCESSORIES

HF-EE

