

# HF-EM 8 5-6

HF-cable clamp for wall fastening

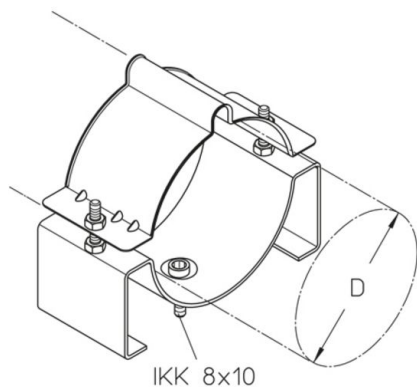

Zinc coated

Product	D	G
HF-EM 8 5	128 (E 26-30) mm	85,8 kg/100
HF-EM 8 6	160 (E 20) mm	100,5 kg/100

**D:** diameter  
**G:** weight

## OPTIONAL ACCESSORIES

HF-EE

