

HF-EL 5-6

HF-cable clamp for wall fastening

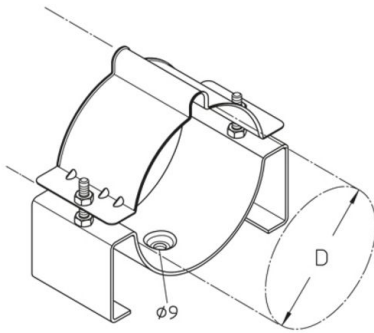

Zinc coated

Product	D	G
HF-EL 5	128 (E 26-30) mm	85 kg/100
HF-EL 6	160 (E 20) mm	99,8 kg/100

D: diameter
G: weight

DETAILS / APPLICATIONS

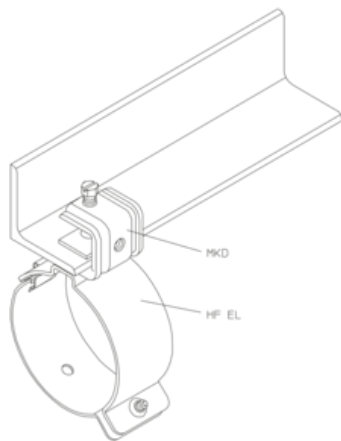



OPTIONAL ACCESSORIES

HF-EE

