

HF-EL 1-4

HF-cable clamp for wall fastening

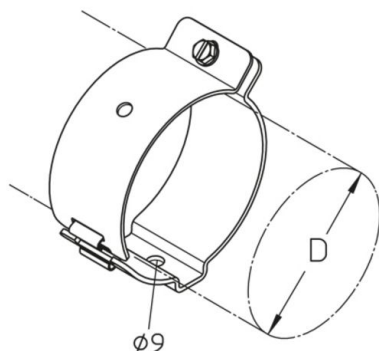

Zinc coated

Product	D	G
HF-EL 1	37 (E 130-190) mm	12,7 kg/100
HF-EL 2	50 (E 78-105) mm	14,1 kg/100
HF-EL 3	62 (E 60-70) mm	16,1 kg/100
HF-EL 4	100 (E 38-46) mm	23,2 kg/100

D: diameter
G: weight

DETAILS / APPLICATIONS

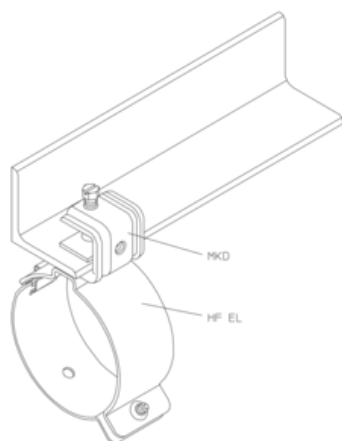

OPTIONAL ACCESSORIES

HF-EE

