

## HF-EAC 5-6

HF-cable clamp for fastening to profile rails

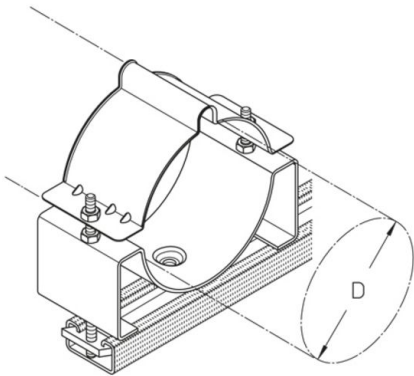

Zinc coated

Product	D	G
HF-EAC 5	128 (E 26-30) mm	96,6 kg/100
HF-EAC 6	160 (E 20) mm	112,6 kg/100

**D:** diameter  
**G:** weight

## DETAILS / APPLICATIONS

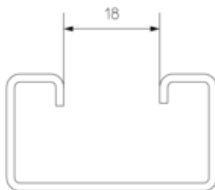

## OPTIONAL ACCESSORIES

A 7, A 8, HF-EE

