

# HF-EAC 1-4

HF-cable clamp for fastening to profile rails

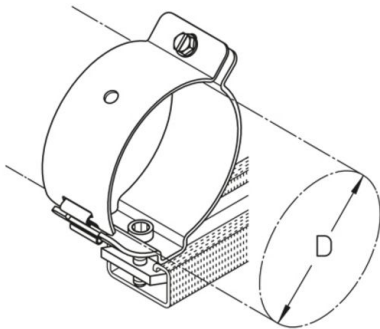

Zinc coated

Product	D	G
HF-EAC 1	37 (E 130-190) mm	17,2 kg/100
HF-EAC 2	50 (E 78-105) mm	18,6 kg/100
HF-EAC 3	62 (E 60-70) mm	20,7 kg/100
HF-EAC 4	100 (E 38-46) mm	27,8 kg/100

**D:** diameter

**G:** weight

## DETAILS / APPLICATIONS

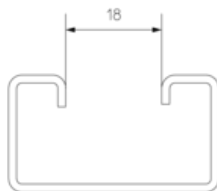

## OPTIONAL ACCESSORIES

HF-EE, A 7, A 8

