

CHALI

screed-flush brush duct

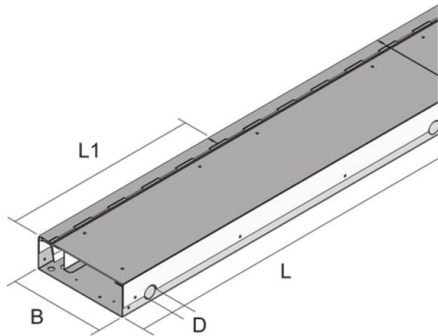

Screed-flush brush duct with coverable brush and removable covers for horizontal cable installation. Consisting of pre-assembled height-adjustable lower and upper part. Designed for office traffic loads. Suitable for rooms with dry and damp-cleaned floor covers.

The levelling range can be adjusted by using levelling feet UBDSL F (UBDSL F: 92 - 160 mm; UBDSL F 150: 158 - 230 mm; UBDSL F 228 - 300 mm). The use of the UGM-SL F impact sound sleeve increases the levelling range by 3 mm. Please note the technical information.

The barrier-free system can be installed directly along the wall, at window fronts as well as in the middle of the room without a trip hazard.



material	Cover: Sheet steel, hot-dip galvanized
type of assembly	Mounting on raw concrete ceiling
application area	dry and damp-cleaned floor covers
norm	according to DIN EN 50085
permits	according to VDE / TÜV

Continuously hot galvanized (Sendzimir process) (DIN EN 10346)

Product	H	B	L	L1	D	E	T	P _{max}	IP _n	IP _g	G
CHALI 85-25S	85 mm	255 mm	2000 mm	500 mm	32 mm	265 mm	25 mm	5 kN	IP 30	IP 20	35,18 kg

- H: height
- B: width
- L: length
- L1: length 1
- D: diameter
- E: fitting dimension
- T: depth
- P_{max}: Maximum load
- IP_n: IP protection level in unused condition



IP_g: IP protection level in used condition
G: weight



dry-cleaned

