

BKA 110

floor duct branch, height = 110 mm

floor duct branch as T-piece with integrated connectors

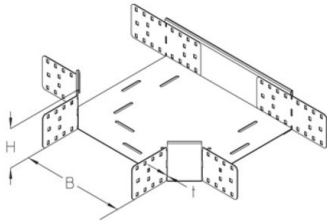

From a width \geq 300 mm, one separating strip must be installed. From a width of \geq 500 mm, two separating strips must be installed.

Continuously hot galvanized (Sendzimir process) (DIN EN 10346)

Product	H	B	t	G
BKA 110-10S	110 mm	100 mm	2,00 mm	2,94 kg
incl.: 6x KLR clamp fastening set				
BKA 110-15S	110 mm	150 mm	2,00 mm	3,39 kg
incl.: 6x KLR clamp fastening set				
BKA 110-20S	110 mm	200 mm	2,00 mm	3,90 kg
incl.: 6x KLR clamp fastening set				
BKA 110-30S	110 mm	300 mm	2,00 mm	5,15 kg
incl.: 6x KLR clamp fastening set				
BKA 110-40S	110 mm	400 mm	2,00 mm	6,76 kg
incl.: 6x KLR clamp fastening set				
BKA 110-50S	110 mm	500 mm	2,00 mm	8,63 kg
incl.: 6x KLR clamp fastening set				
BKA 110-60S	110 mm	600 mm	2,00 mm	10,85 kg
incl.: 6x KLR clamp fastening set				



H: height
B: width
t: material thickness
G: weight

DETAILS / APPLICATIONS

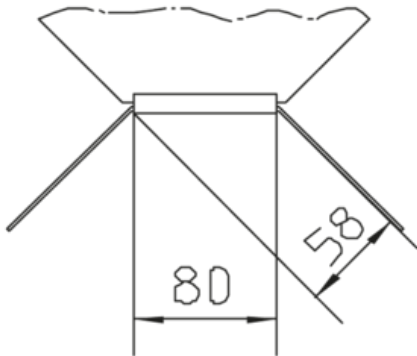

OPTIONAL ACCESSORIES

BKADR, BKADR-RHP, BKADR-WZB AL, BKRTV 110, BKDS 110

