

AMF18

channel spring nut, A7/A8

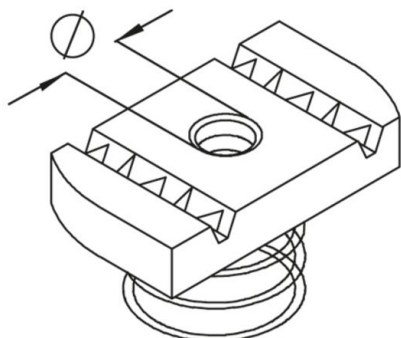

galvanized, according to DIN EN ISO 19598 / DIN EN ISO 2081

Product	Ø	t	G
AMF18 M6	6 mm	6,00 mm	2,7 kg/100
AMF18 M8	8 mm	6,00 mm	2,5 kg/100
AMF18 M10	10 mm	8,00 mm	3,4 kg/100
AMF18 M12	12 mm	9,50 mm	4,3 kg/100

Hot-dip galvanized, according to BS 729 (DIN EN ISO 1461)

Product	Ø	t	G
AMF18 M6F	6 mm	6,00 mm	2,9 kg/100
AMF18 M8F	8 mm	6,00 mm	2,7 kg/100
AMF18 M10F	10 mm	8,00 mm	3,6 kg/100
AMF18 M12F	12 mm	9,50 mm	4,6 kg/100

Ø: diameter
t: material thickness
G: weight

DETAILS / APPLICATIONS



