

AC-IW

cable clamp with additional insulating vat for fastening to C-profile rails

Cable clamp with full-surface vat made of galvanised steel and additional insulating vat made of polystyrene. For fastening to C-profile rails (C+, C60°) with a slot size of 18/22 mm.

Zinc coated

Product	D	H _{max}	M	number of cables	G
12 AC-IW	8-12 mm	42,5 mm	2 Nm	1	2,8 kg/100
16 AC-IW	12-16 mm	47,5 mm	2 Nm	1	3,2 kg/100
20 AC-IW	16-20 mm	51,5 mm	2 Nm	1	3,6 kg/100
24 AC-IW	20-24 mm	55,7 mm	2 Nm	1	4,2 kg/100
28 AC-IW	24-28 mm	59,7 mm	2 Nm	1	4,5 kg/100
32 AC-IW	28-32 mm	65 mm	2 Nm	1	7,1 kg/100
36 AC-IW	32-36 mm	69 mm	2 Nm	1	7,5 kg/100
40 AC-IW	36-40 mm	73 mm	2 Nm	1	8,2 kg/100
44 AC-IW	40-44 mm	83 mm	4 Nm	1	10,2 kg/100
48 AC-IW	44-48 mm	87 mm	4 Nm	1	10,6 kg/100
52 AC-IW	48-52 mm	92,5 mm	4 Nm	1	11,6 kg/100
56 AC-IW	52-56 mm	96,5 mm	4 Nm	1	12,2 kg/100
60 AC-IW	56-60 mm	100,5 mm	4 Nm	1	15,9 kg/100
64 AC-IW	60-64 mm	104,5 mm	4 Nm	1	17,5 kg/100
70 AC-IW	64-70 mm	111,5 mm	4 Nm	1	18,6 kg/100

D: diameter

H_{max}: Maximum height

M: torque

number of cables: Maximum number of installable cables

G: weight



DETAILS / APPLICATIONS

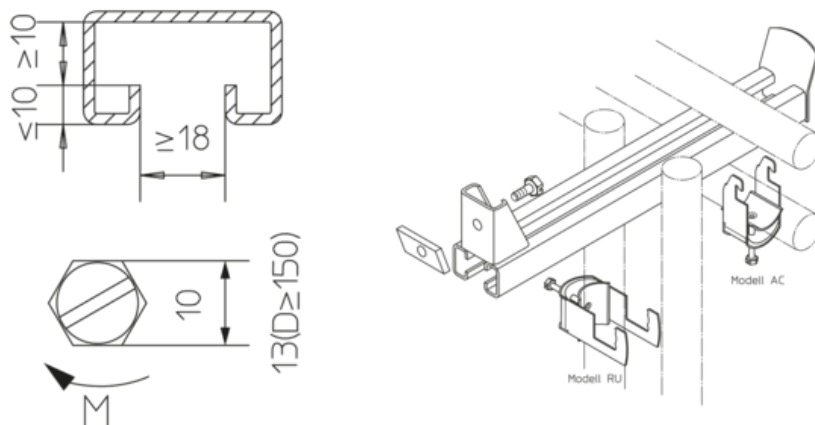

OPTIONAL ACCESSORIES

A 41, A 2, A 4, A 9, A 8, A 7, KHA 21, KHA 41

