

WPSD

Wide-span riser cover

The wide-span riser cover WPSD is suitable for WPLS wide-span risers and protects them from dirt, moisture and UV radiation. It is placed on top of the riser and secured with WPFDK formed part cover clips. It can be elevated on request. The cover has a radius of 450 mm corresponding to the riser. We provide components in various materials and surface finishes to ensure that various corrosion protection requirements for different areas of application are met.

steel, continuously hot galvanized/Sendzimir process

Products	B	R	direction	α	W
WPSD 20S	251 mm	450 mm	vertically rising	90°	1,910 kg
WPSD 30S	351 mm	450 mm	vertically rising	90°	3,500 kg
WPSD 40S	451 mm	450 mm	vertically rising	90°	4,480 kg
WPSD 50S	551 mm	450 mm	vertically rising	90°	6,810 kg
WPSD 60S	651 mm	450 mm	vertically rising	90°	8,030 kg

steel, batch/hot-dip galvanized

Products	B	R	direction	α	W
WPSD 20F	251 mm	450 mm	vertically rising	90°	2,040 kg
WPSD 30F	351 mm	450 mm	vertically rising	90°	3,750 kg
WPSD 40F	451 mm	450 mm	vertically rising	90°	4,790 kg
WPSD 50F	551 mm	450 mm	vertically rising	90°	7,290 kg
WPSD 60F	651 mm	450 mm	vertically rising	90°	8,590 kg

Stainless steel, according to ASTM 304 / BS 304 S 3

Products	B	R	direction	α	W
WPSD 20E	251 mm	450 mm	vertically rising	90°	1,910 kg



PRODUCT INFORMATION

Products	B	R	direction	α	W
WPSD 30E	351 mm	450 mm	vertically rising	90°	3,500 kg
WPSD 40E	451 mm	450 mm	vertically rising	90°	4,480 kg
WPSD 50E	551 mm	450 mm	vertically rising	90°	6,810 kg
WPSD 60E	651 mm	450 mm	vertically rising	90°	8,030 kg

B: width
R: radius
direction:

α

:

W: Weight per storage unit

DETAIL AND APPLICATION IMAGES

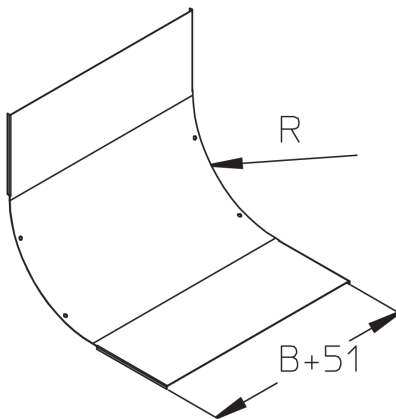

WPFDK / WPFDKA	
WPAD 20 - WPAD 60	6x
WPBD 20 - WPBD 40	4x
WPBD 50 - WPBD 60	5x
WPFD 20 - WPFD 60	4x
WPKD 20 - WPKD 60	8x
WPSD 20 - WPSD 60	4x

OPTIONAL ACCESSORIES

WPFDK 100, WPFDK 120, WPFDK 150

