

## WPRF 100

Wide-span cable tray riser, height = 100 mm

The wide-span cable tray riser WPRF 100 with integrated connectors allows the direction of cable routing to be changed vertically by 90° downwards. It is suitable for wide-span cable trays with rails 100 mm high and is 200 to 600 mm wide. The riser is pushed into the wide-span cable tray and then bolted in place. The connecting cable tray is then mounted on the riser. It has a radius of 510 mm.

Stainless steel, according to ASTM 304 / BS 304 S 3

Products	H	B	L	R			W
WPRF 100-20E	100 mm	200 mm	550 mm	510 mm	90 °	VERTIKAL-FALLEND	7,674 kg
incl.:							
8 × FRSV 10X20E, 8 × SEMS 10E							
WPRF 100-30E	100 mm	300 mm	550 mm	510 mm	90 °	VERTIKAL-FALLEND	8,344 kg
incl.:							
8 × FRSV 10X20E, 8 × SEMS 10E							
WPRF 100-40E	100 mm	400 mm	550 mm	510 mm	90 °	VERTIKAL-FALLEND	9,024 kg
incl.:							
8 × FRSV 10X20E, 8 × SEMS 10E							
WPRF 100-50E	100 mm	500 mm	550 mm	510 mm	90 °	VERTIKAL-FALLEND	9,714 kg
incl.:							
8 × FRSV 10X20E, 8 × SEMS 10E							
WPRF 100-60E	100 mm	600 mm	550 mm	510 mm	90 °	VERTIKAL-FALLEND	10,394 kg
incl.:							
8 × FRSV 10X20E, 8 × SEMS 10E							

**H:** height  
**B:** width  
**L:** length  
**R:** radius  
**W:** Weight per storage unit



# PRODUCT INFORMATION

---

## DETAIL AND APPLICATION IMAGES

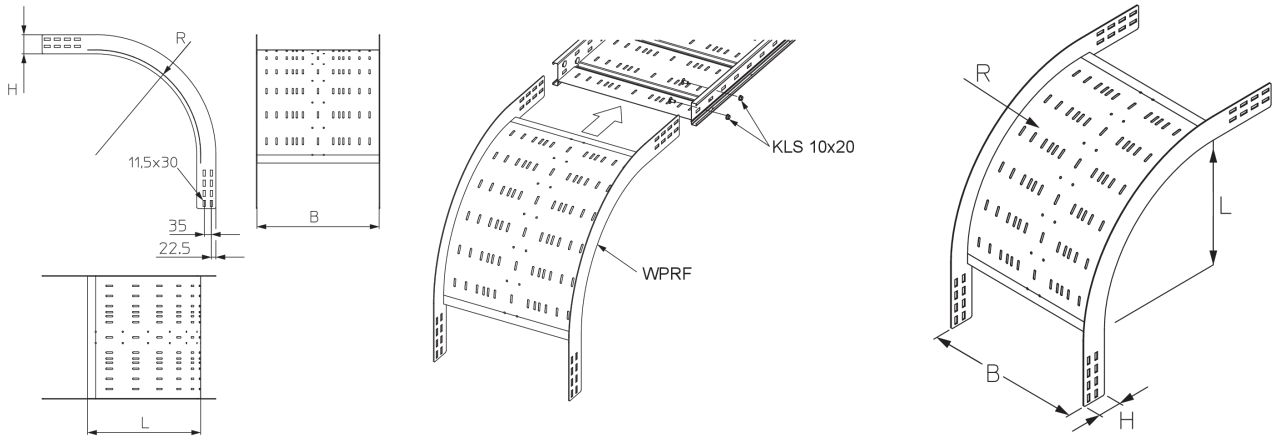

## OPTIONAL ACCESSORIES

WPFD

