

## WPRAA 100

Wide-span cable tray attachment branch, height = 100 mm

The wide-span cable tray attachment branch WPRAA 100 with integrated side connectors enables the direction of cable routing to be changed in the form of a branch. It is suitable for wide-span cable trays with rails 100 mm high and is 200 to 600 mm side. The side rail of the main tray is cut out at the point where the connecting tray will branch off. The WPRAA attachment branch is positioned and bolted in place at this point. The connection tray can then be pushed in with a VB floor connector. We provide components in various materials and surface finishes to ensure that various corrosion protection requirements for different areas of application are met.

Stainless steel, according to ASTM 304 / BS 304 S 3

Products	Height	B	L	R	W
WPRAA 100-20E	100 mm	200 mm	1635 mm	450 mm	8,358 kg
incl.:					
16 x FRSV 10X20E, 16 x SEMS 10E					
WPRAA 100-30E	100 mm	300 mm	1735 mm	450 mm	8,868 kg
incl.:					
16 x FRSV 10X20E, 16 x SEMS 10E					
WPRAA 100-40E	100 mm	400 mm	1835 mm	450 mm	9,378 kg
incl.:					
16 x FRSV 10X20E, 16 x SEMS 10E					
WPRAA 100-50E	100 mm	500 mm	1935 mm	450 mm	9,888 kg
incl.:					
16 x FRSV 10X20E, 16 x SEMS 10E					
WPRAA 100-60E	100 mm	600 mm	2035 mm	450 mm	10,408 kg
incl.:					
16 x FRSV 10X20E, 16 x SEMS 10E					

**B:** width  
**L:** length  
**R:** radius  
**W:** Weight per storage unit



# PRODUCT INFORMATION

---

## DETAIL AND APPLICATION IMAGES

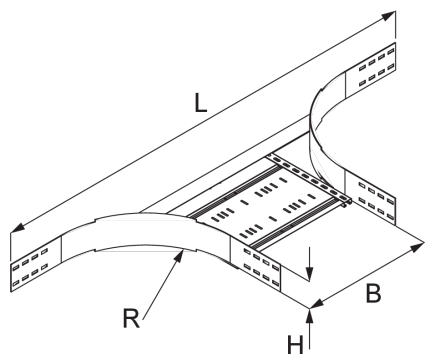

## OPTIONAL ACCESSORIES

WPAD, WPTRV 100

