

WPD-A

Cover elevator

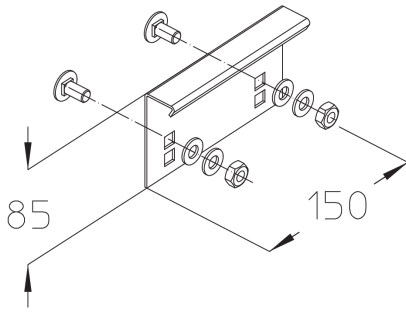

The cover elevator WPD-A is used to elevate wide-span covers to improve the ventilation of cables. The covers must be secured with cover clips. At least 6 cover elevators and cover clamps must be used per 3 metres of cable tray cover according to the installation instructions. In wind-exposed areas, the number must be increased to at least ten WPD-A and WPDUK per 3 m. Whether elevated or not, the filling volume of the ladder remains unchanged. We provide components in various materials and surface finishes to ensure that various corrosion protection requirements for different areas of application are met.

steel, continuously hot galvanized/Sendzimir process

Products	H	B	L	weight
WPD-A S	85 mm	29 mm	150 mm	0,347 kg
incl.:				
2 × KLS 10X20, 2 × UVS M10				

steel, batch/hot-dip galvanized

Products	H	B	L	weight
WPD-A F	85 mm	29 mm	150 mm	0,343 kg
incl.:				
2 × UVS M10, 2 × KLS 10X20F				

Stainless steel, according to ASTM 304 / BS 304 S 3

Products	H	B	L	weight
WPD-A E	85 mm	29 mm	150 mm	0,365 kg
incl.:				
2 × KLS 10X20E, 2 × UVS M10				



PRODUCT INFORMATION

H: height
B: width
L: length

DETAIL AND APPLICATION IMAGES

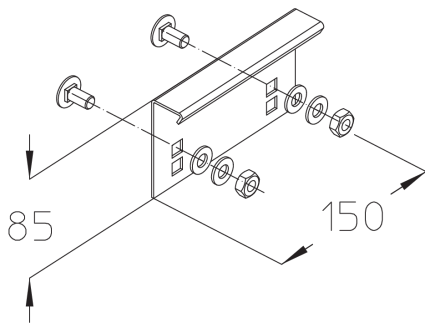

OPTIONAL ACCESSORIES

WPDUK

