

## WLKLT

### Wide-span cable ladder clamp

The clamping fastener WLKLT is an accessory part for the WLHS wide-span side rail support if it is used to secure the position of a WL or WLR 200 wide-span tray on steel beams. It is made of hot-dip galvanized steel.

steel, batch/hot-dip galvanized

Products	H	B	L	k	SW	M	weight
WLKLT F	45 mm	64 mm	30 mm	3 - 25 mm	10 mm	4,0 Nm	0,137 kg

**H:** height  
**B:** width  
**L:** length  
**k:** clamping range  
**SW:** wrench size  
**M:** torque

## DETAIL AND APPLICATION IMAGES

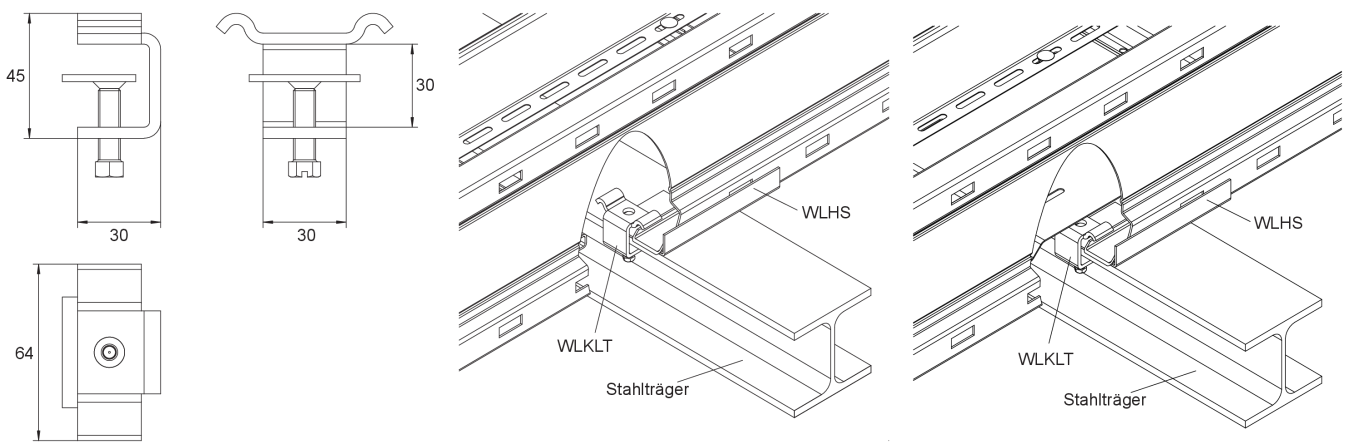

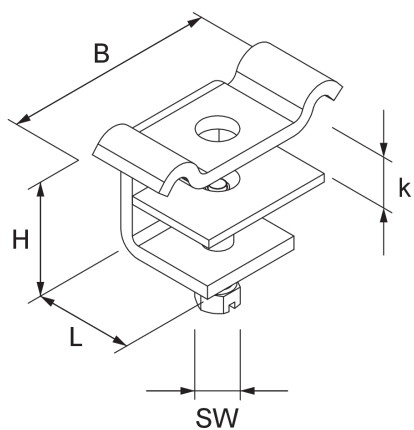

## OPTIONAL ACCESSORIES

WLHS

