

WLKL

Wide-span cable ladder clamp attachment

The clamping fastener WLKL is an accessory part for the WLHS wide-span side rail support if it is used to secure the position of a WL or WLR 200 wide-span tray on brackets of type KWS. We provide components in various materials and surface finishes to ensure that various corrosion protection requirements for different areas of application are met.

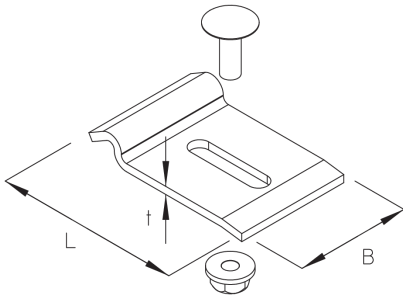

steel, continuously hot galvanized/Sendzimir process

Products	t	W
WLKL S	3,00 mm	0,128 kg
incl.:		
1 x FRSV 6X16, 1 x SEMS 6		

steel, batch/hot-dip galvanized

Products	t	W
WLKL F	3,00 mm	0,130 kg
incl.:		
1 x FRSV 6X16E, 1 x SEMS 6E		

t: material thickness
W: Weight per storage unit

DETAIL AND APPLICATION IMAGES



PRODUCT INFORMATION

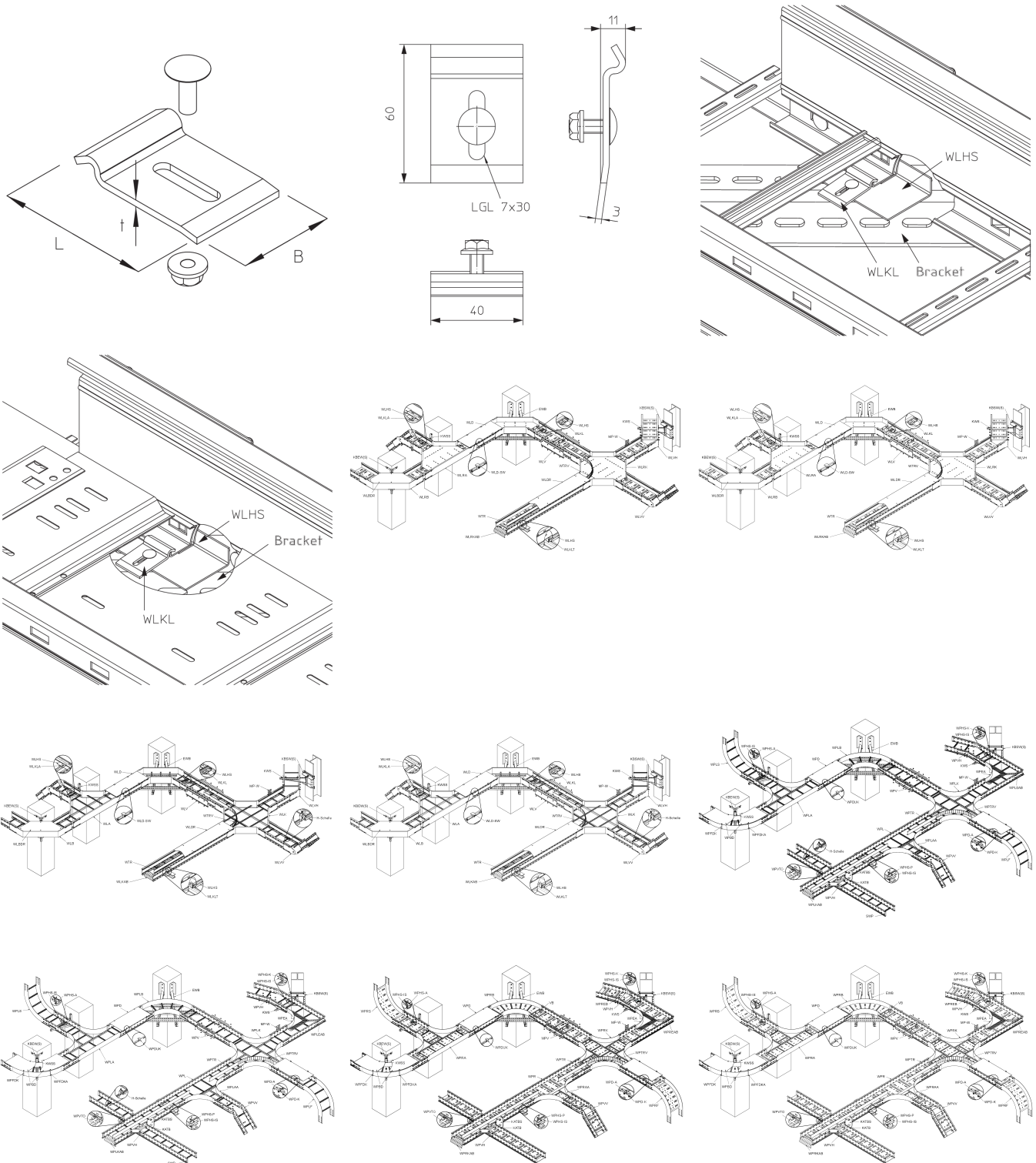

OPTIONAL ACCESSORIES

WLHS

