

## VB-BS

Floor connector, maintenance of function

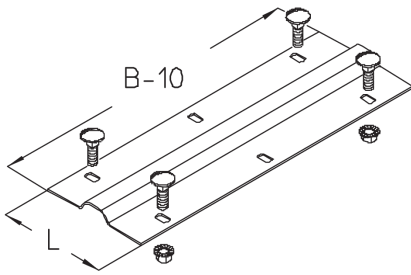

steel, continuously hot galvanized/Sendzimir process

Products	B	L	weight
VB-BS 10S	84 mm	99 mm	0,098 kg
incl.:			
1 × KLR			
VB-BS 20S	184 mm	99 mm	0,209 kg
incl.:			
2 × KLR			
VB-BS 30S	284 mm	99 mm	0,312 kg
incl.:			
2 × KLR			
VB-BS 40S	384 mm	99 mm	0,425 kg
incl.:			
2 × KLR			
VB-BS 50S	484 mm	99 mm	0,523 kg
incl.:			
2 × KLR			
VB-BS 60S	584 mm	99 mm	0,599 kg
incl.:			
2 × KLR			



# PRODUCT INFORMATION

steel, batch/hot-dip galvanized

Products	B	L	weight
VB-BS 10F	84 mm	99 mm	0,103 kg
incl.: 1 × KLR E			
VB-BS 20F	184 mm	99 mm	0,226 kg
incl.: 2 × KLR E			
VB-BS 30F	284 mm	99 mm	0,327 kg
incl.: 2 × KLR E			
VB-BS 40F	384 mm	99 mm	0,450 kg
incl.: 2 × KLR E			

**B:** width  
**L:** length

## DETAIL AND APPLICATION IMAGES

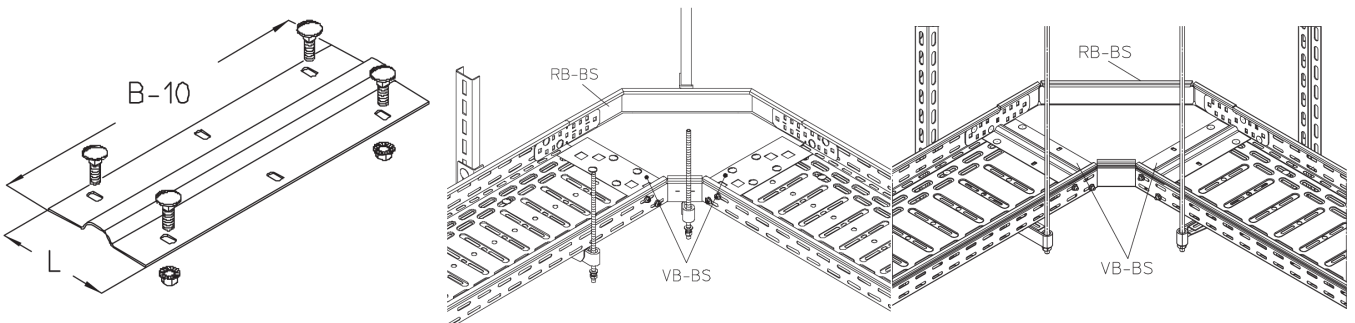

Page 2



PohlCon GmbH  
Nobelstraße 51 | 12057 Berlin  
Telefon: +49 30 68283-04 | Fax: +49 30 68283-383 | [contact@pohlcon.com](mailto:contact@pohlcon.com)



# PRODUCT INFORMATION

