

UNE

Levelling unit, dummy, 3x, angular

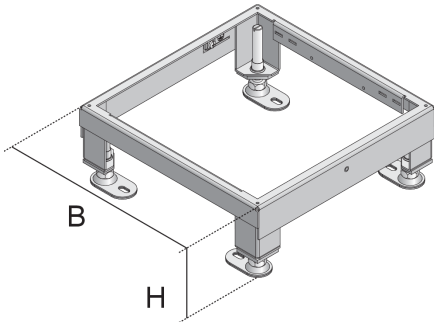

UNE components are square, dummy levelling units consisting of a sheet steel frame, internal level adjusters with levelling bases and earthing clamps. The units are mounted on stainless steel cartridges and used in floor sockets, assembly covers and raised or false floor openings in rooms with high traffic loads. They are made of sendzimir hot-dip galvanised steel (DIN EN 10346) and have installation dimensions of 261 x 261 mm.



Products	H _{min}	N	B	L	E	P _{max}	W
UNE 260V-30S	65 mm	25 mm	260 mm	260 mm	261 x 261 mm	20,00 kN	1,364 kg
UNE 260V-60S	90 mm	45 mm	260 mm	260 mm	261 x 261 mm	20,00 kN	1,472 kg
UNE 260V-100S	135 mm	45 mm	258 mm	258 mm	261 x 261 mm	20,00 kN	1,648 kg
UNE 260V-155S	155 mm	95 mm	258 mm	258 mm	261 x 261 mm	10,00 kN	1,764 kg
UNE 260V-210S	212 mm	100 mm	258 mm	258 mm	261 x 261 mm	10,00 kN	2,036 kg

H_{min}: minimum installation height

N: levelling range

B: width

L: length

E: fitting dimension

P_{max}: maximum load

W: Weight per storage unit

DETAIL AND APPLICATION IMAGES



PRODUCT INFORMATION

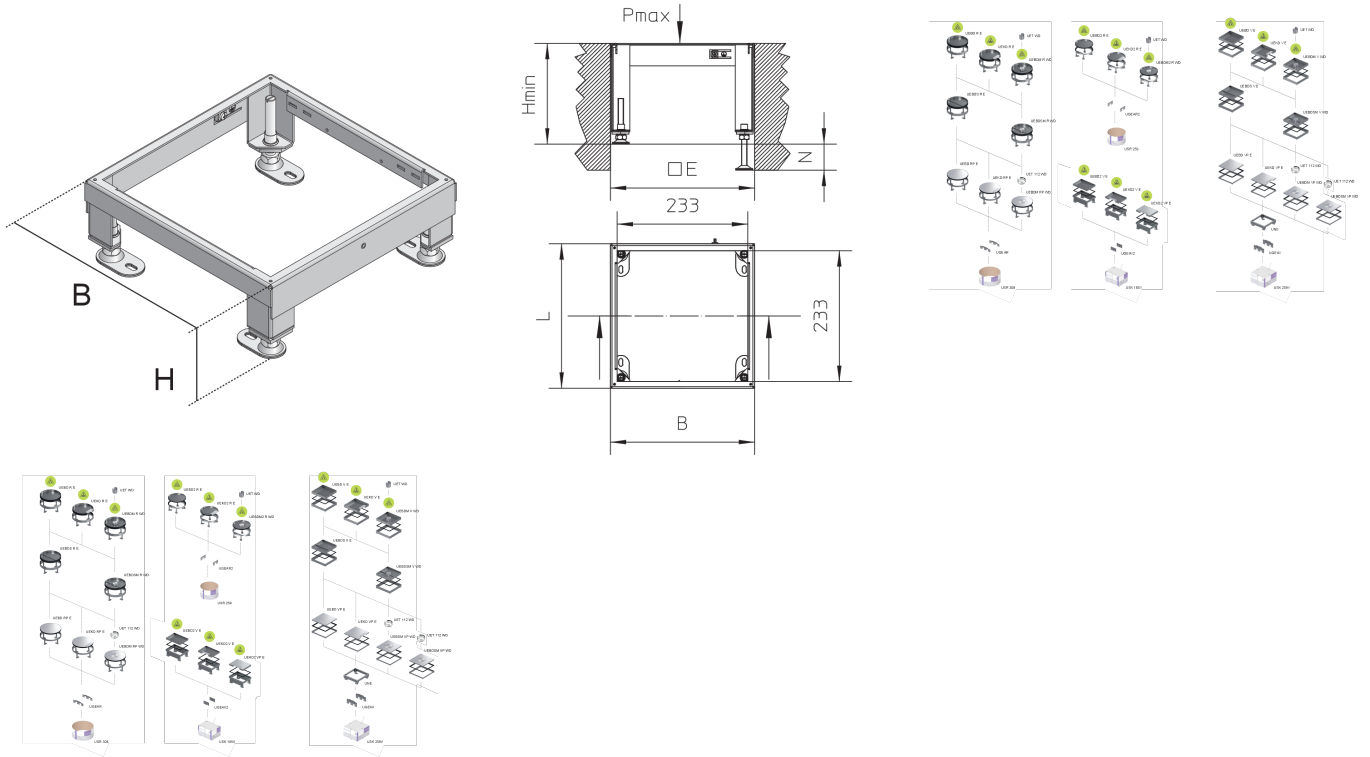

OPTIONAL ACCESSORIES

UGEAV, UGM SLF

DIN

Load requirements according to, DIN EN 50085

