

UK

Screed-covered duct, two sections

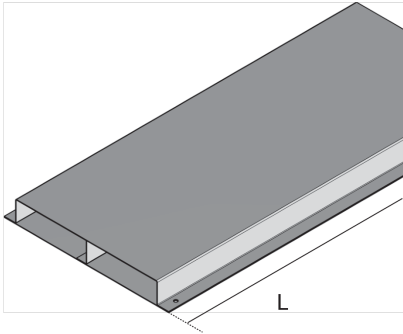

UK is a screed-covered, two-section underfloor duct manufactured as a closed rectangular profile made of sendzimir hot-dip galvanized sheet steel in accordance with DIN EN 10346. They are DIN EN 50085 VDE/TÜV certified and can withstand loads of up to 0.75 kN. They come in versions from 190 to 350 mm wide, are 3000 mm long and 28 to 48 mm high. The systems consist of the duct bottom part with two separating strips and the duct top part. The bottom and top parts are firmly connected to each other and have integrated drill holes in the side fold. The separating strip allows cables to be routed in two sections. Additional accessories are optionally available.



steel, continuously hot galvanized/Sendzimir process

Products	H	B	B1	B2	L	P _{max}	W
UK 2-28-190S	28 mm	190 mm	95 mm	95 mm	3000 mm	0,75 kN	11,622 kg
UK 2-28-250S	28 mm	250 mm	125 mm	125 mm	3000 mm	0,75 kN	14,095 kg
UK 2-28-350S	28 mm	350 mm	175 mm	175 mm	3000 mm	0,75 kN	20,800 kg
UK 2-38-190S	38 mm	190 mm	95 mm	95 mm	3000 mm	0,75 kN	12,329 kg
UK 2-38-250S	38 mm	250 mm	125 mm	125 mm	3000 mm	0,75 kN	14,802 kg
UK 2-38-350S	38 mm	350 mm	175 mm	175 mm	3000 mm	0,75 kN	21,566 kg
UK 2-48-190S	48 mm	190 mm	95 mm	95 mm	3000 mm	0,75 kN	13,035 kg
UK 2-48-250S	48 mm	250 mm	125 mm	125 mm	3000 mm	0,75 kN	15,455 kg
UK 2-48-350S	48 mm	350 mm	175 mm	175 mm	3000 mm	0,75 kN	22,390 kg

H: height

B: width

B1: width

B2: width

L: length

P_{max}: maximum load

W: Weight per storage unit

DETAIL AND APPLICATION IMAGES



PRODUCT INFORMATION

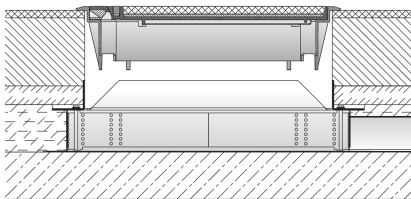
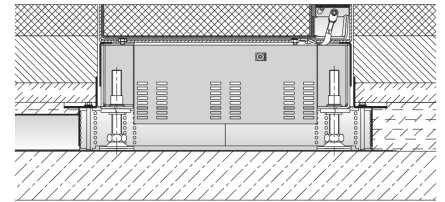
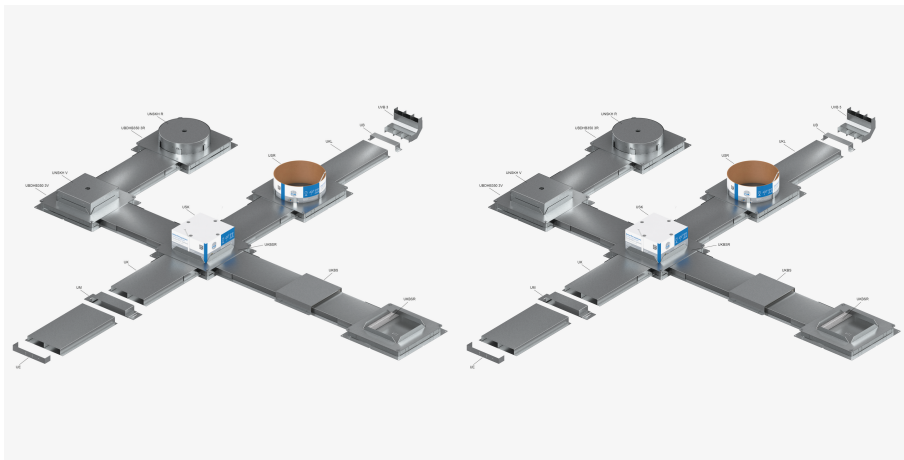
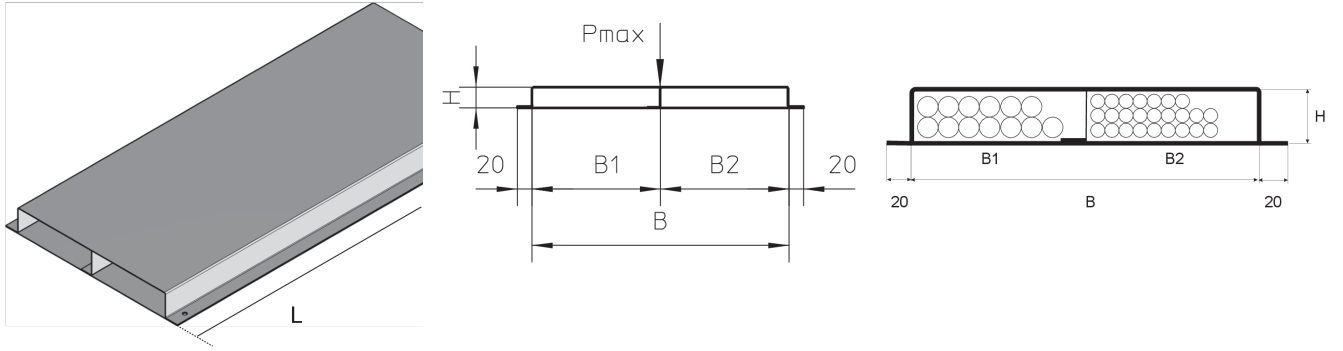

OPTIONAL ACCESSORIES

UB, UGKB, UN



DIN

Load requirements according to, DIN EN 50085

