

PRODUCT INFORMATION

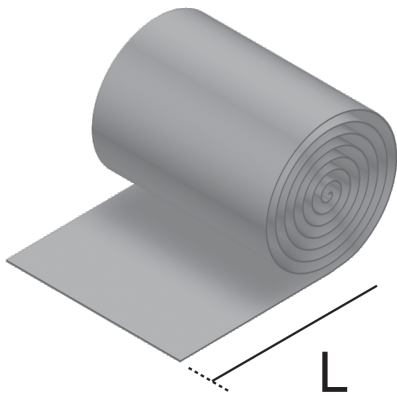

UGKB

Duct tape

UGKB products are fabric adhesive tapes that are mounting components from the screed-covered underfloor duct product range. The adhesive tapes are used to securely seal all open areas to prevent possible screed penetration during installation of the duct systems. For example, the tapes create a secure and impermeable attachment when installing formwork bodies in the channels. The components are made of the high-quality plastic polyethylene terephthalate. They are 50 mm wide and 50 m long.

Products	B	L	W
UGKB	40 mm	25000 mm	0,588 kg

B: width
L: length
W: Weight per storage unit

DETAIL AND APPLICATION IMAGES

