

## UGET 3 SCS

Mounting box assembly carrier, fibre-optic technology

UGET 3 SCS components are mounting box assembly carriers from the underfloor systems range. The installation supports are bolted into the UG mounting boxes and are used to accommodate a maximum of 3 SC simplex or SC duplex fibre-optic data jacks. They are made of sendzimir hot-dip galvanized sheet steel in accordance with DIN EN 10346 in black (similar to RAL 9011) and are available with installation dimensions of E1 13.5 mm and E2 9.6 mm.

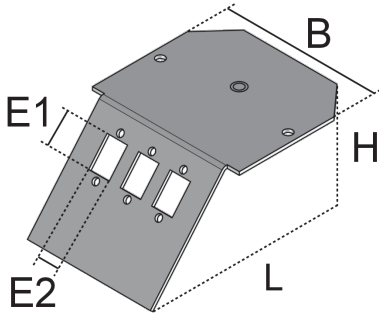

steel, continuously hot galvanized/Sendzimir process

Products	H	B	L	E1	E2	color	data jacks	weight
UGET-3-SCS 113	42 mm	69 mm	107 mm	13,5 mm	9,6 mm	9011	3	0,082 kg

H: height  
 B: width  
 L: length  
 E1: fitting dimension E1  
 E2: fitting dimension E2  
**data jacks:**

## DETAIL AND APPLICATION IMAGES

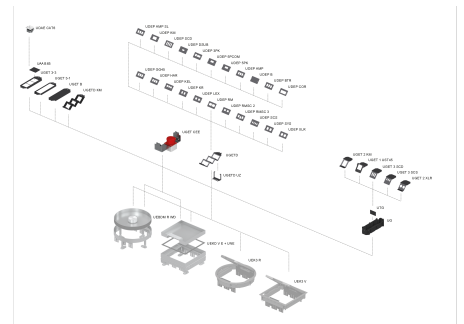
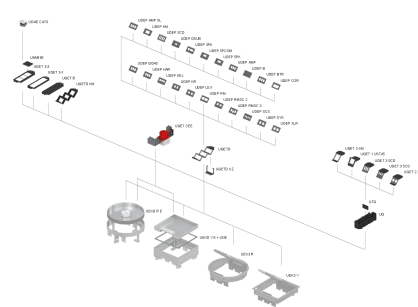
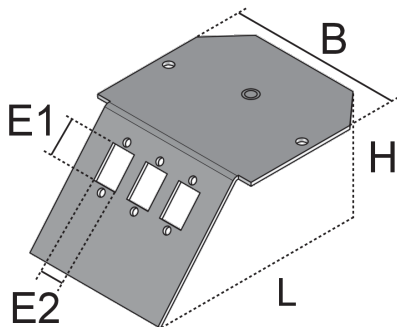

## OPTIONAL ACCESSORIES

UG

