

UGET 3 SCD

Mounting box assembly carrier, fibre-optic technology

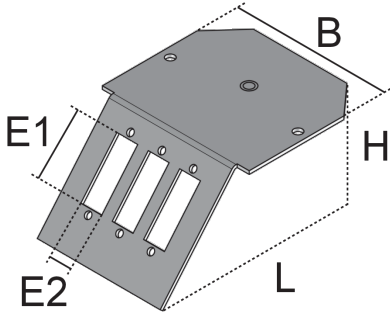

UGET 3 SCD components are mounting box assembly carriers from the underfloor systems range. The installation supports are bolted into UG mounting boxes and are used to accommodate a maximum of 3 SC duplex fibre-optic data jacks. They are made of sendzimir hot-dip galvanized sheet steel in accordance with DIN EN 10346 in black (similar to RAL 9011) and are available with installation dimensions of E1 26.4 mm and E2 9.8 mm.

steel, continuously hot galvanized/Sendzimir process

Products	H	B	L	E1	E2	color	data jacks	weight
UGET-3-SCD 113	42 mm	69 mm	107 mm	26,4 mm	9,8 mm	9011	3	0,078 kg

H: height
 B: width
 L: length
 E1: fitting dimension E1
 E2: fitting dimension E2
data jacks:

DETAIL AND APPLICATION IMAGES

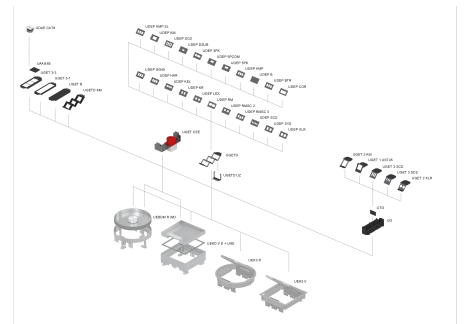
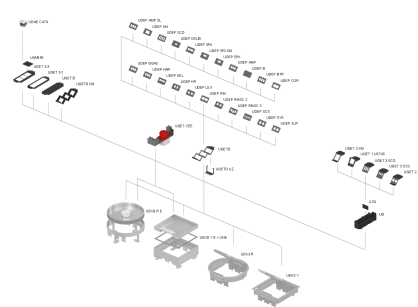
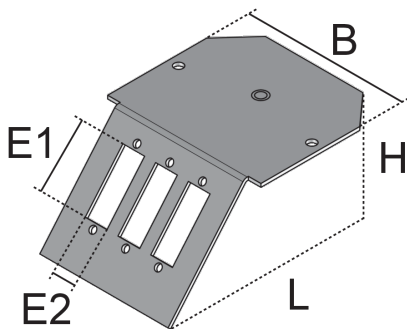

OPTIONAL ACCESSORIES

UG

