

UGET 1 UST45

Mounting box assembly carrier installation devices

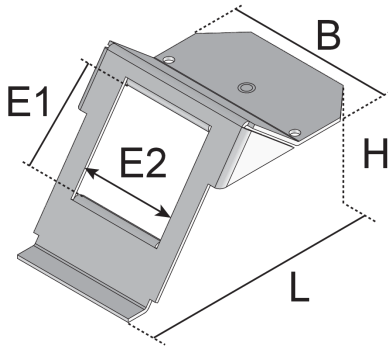

UGET 1 UST45 components are mounting box assembly carriers from the underfloor systems range. The installation supports are bolted into the UG mounting boxes and are used to accommodate an installation device with dimensions 45x45 mm made by PEHA, Legrand or Simon. The device carriers are made of sendzimir hot-dip galvanised sheet steel in accordance with DIN EN 10346 in black (similar to RAL 9011) and are available with installation dimensions of E1 40.5 mm and E2 40.5 mm.

steel, continuously hot galvanized/Sendzimir process

Products	H	B	L	E1	E2	color	installation units/outlet socket	data jacks	W
UGET-1-UST45 113	42 mm	69 mm	107 mm	40,5 mm	40,5 mm	RAL 9011 (graphite black)	1x 45x45 mm	1	0,094 kg

H: height

B: width

L: length

E1: fitting dimension E1

E2: fitting dimension E2

installation units/outlet socket: max. number of installation units

data jacks:

W: Weight per storage unit

DETAIL AND APPLICATION IMAGES



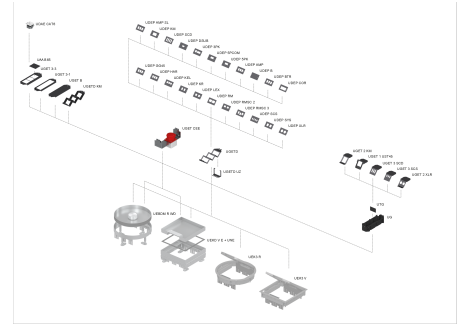
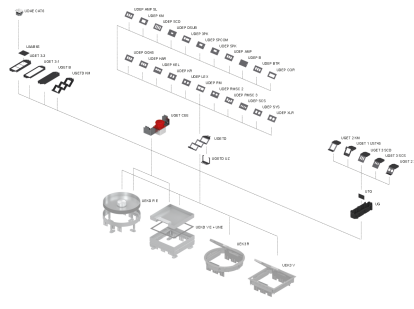
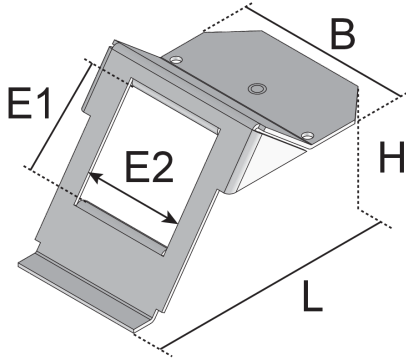

OPTIONAL ACCESSORIES

UG

