

UET112 WD

Tube

The UET112 WD component is a tube that serves as a raised cable outlet. It is bolted onto a UEEDM P square or round tube outlet cartridge using a tube mounting kit. This product from the underfloor system range is made of anodised aluminium or stainless steel with an aluminium finish and is suitable for use in wet-cleaned rooms with high traffic loads. This accessory from the range of installation units is made of stainless steel, is 36 mm high, has an inner width of 94 mm, an outer width of 112 mm and weighs 0.15 kg.



| Products | H | B1 | B2 | color | weight |
|-------------|-------|--------|-------|-----------|----------|
| UET112-R-WD | 44 mm | 112 mm | 94 mm | ALUMINIUM | 0,183 kg |

H: height
B1: width
B2: width

DETAIL AND APPLICATION IMAGES

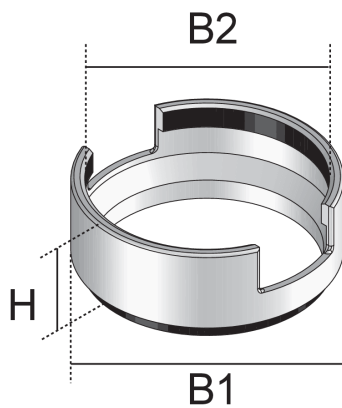

OPTIONAL ACCESSORIES

UETD112 WD



wet maintained



Load requirements according to, DIN EN 50085

