

UEKD2 R

Plastic hinged cover unit, 2x, round

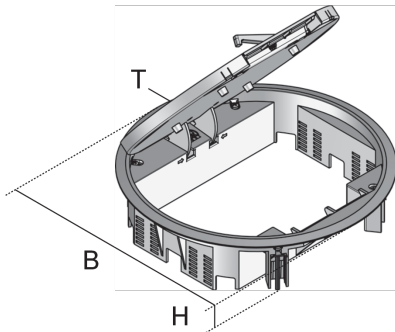

UEKD2 R installation units are round hinged cover units with carpet protection frames that are used in dry-cleaned rooms in assembly covers, floor sockets and in raised or false floor openings. They are designed for office traffic loads and can be used to gradually lower two mounting boxes when supplemented with snap-in ladders. The units have floor-level, swivelling cable outlets, opening levers and universal claws. The cover and frame are made of polyamide in graphite black (RAL 9011) and iron grey (RAL 7011). They have an IP protection rating of IP 30 in an unused condition and an IP protection rating of IP 20 when used. Their minimum installation height is 74 mm, they have a maximum load of 2 kN and installation dimensions of 260 mm.



Products	H	H _{min}	B	E	P _{max}	IP _g	IP _n	color	T	mounting box	ø ext		W
UEKD2-R-G	65 mm	74 mm	280 mm	260 mm	2,00 kN	IP 20	IP 30	RAL 7011 (iron gray)	8 mm	2	280 mm	KUNSTSTOFF	1,391 kg
incl.: 1 x UDKS-R 4													
UEKD2-R-S	65 mm	74 mm	280 mm	260 mm	2,00 kN	IP 20	IP 30	RAL 9011 (graphite black)	8 mm	2	280 mm	KUNSTSTOFF	1,391 kg
incl.: 1 x UDKS-R 4													

H: height
H_{min}: minimum installation height
B: width
E: fitting dimension
P_{max}: maximum load
IP_g: IP protection level in used condition
IP_n: IP protection level in unused condition



PRODUCT INFORMATION

T: Depth of flooring recess
mounting box: maximum number of installable device casings
Ø ext:
W: Weight per storage unit

DETAIL AND APPLICATION IMAGES

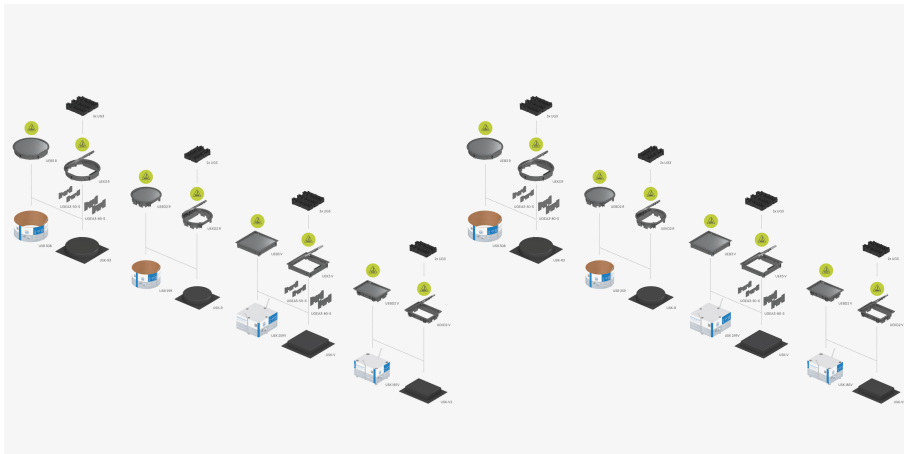
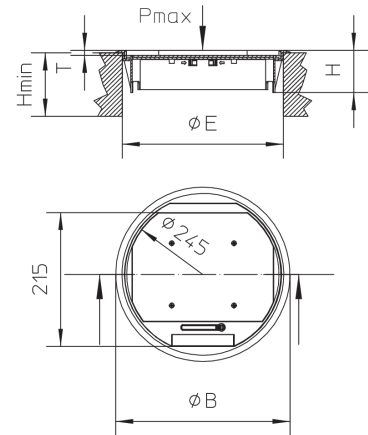
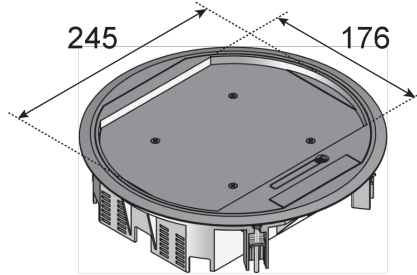
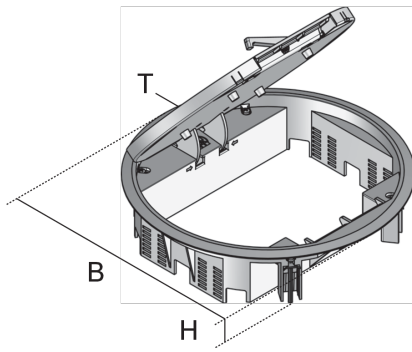

OPTIONAL ACCESSORIES

UEKD R, UDKS 40-80, UDKSEB



dry maintained



Load requirements according to, DIN EN 50085

