

UEBSE

Earth connector

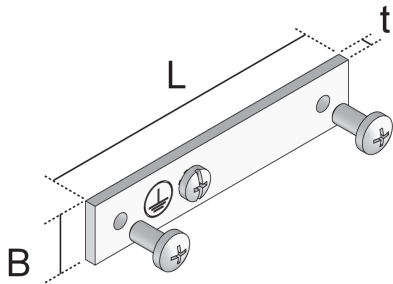

UEBSE components are earthing connectors for screed-flush ducts. The connectors are used to safely connect earthing and equipotential bonding lines when earthing duct trays. Two LKS M5X10 button head screws and one LKS M4X5 button head screw are included for assembly purposes. The connectors are made of sendzimir hot-dip galvanised sheet steel according to DIN EN 10346.



Products	W
UEBSE	0,023 kg
incl.:	
2 x LKS M5X10, 1 x LKS M4X5	

W: Weight per storage unit

DETAIL AND APPLICATION IMAGES

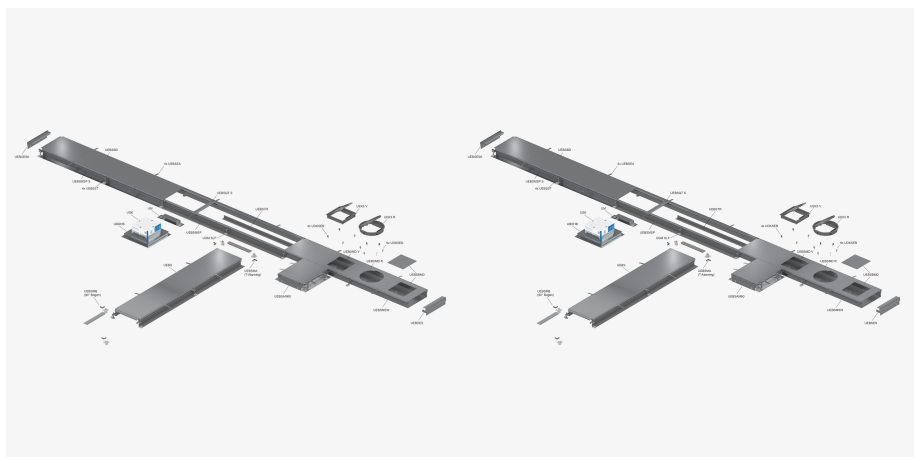
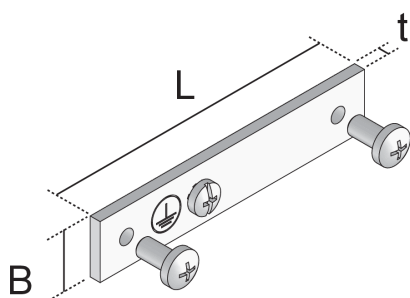

Load requirements according to, DIN EN 50085

