

## UEBD2 R

Plastic dummy cover unit, 2x, round

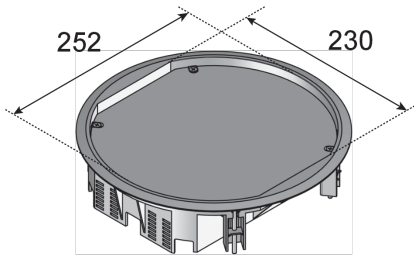

The UEBD2 R product solutions are round dummy cover units with carpet protection frames. They are used in dry-cleaned rooms in assembly covers, UBDHB floor sockets and raised or false floor openings. They are designed for office traffic loads and are used as mounting frames for two mounting boxes. The covers and frames are made of polyamide with matt surfaces in graphite black (RAL 9011) and iron grey (RAL 7011). They are supplied with the universal fastening claw sets and have an IP protection class of IP 30 in an unused condition. Their min. installation height is 65 mm, they are 280 mm wide, have a max. load of 2 kN and installation dimensions of 260 mm.



Products	H	H <sub>min</sub>	B	E	P <sub>max</sub>	IP <sub>n</sub>	color	T	mounting box	ø ext	weight
UEBD2-R-G	65 mm	65 mm	280 mm	260 mm	2,00 kN	IP-30	7011	8 mm	2	280 mm	1,457 kg
incl.: 1 x UDBS-R 4											
UEBD2-R-S	65 mm	65 mm	280 mm	260 mm	2,00 kN	IP-30	9011	8 mm	2	280 mm	1,457 kg
incl.: 1 x UDBS-R 4											

**H:** height

**H<sub>min</sub>:** minimum installation height

**B:** width

**E:** fitting dimension

**P<sub>max</sub>:** maximum load

**IP<sub>n</sub>:** IP protection level in unused condition

**T:** Depth of flooring recess

**mounting box:** maximum number of installable device casings

**Ø ext:**



# PRODUCT INFORMATION

## DETAIL AND APPLICATION IMAGES

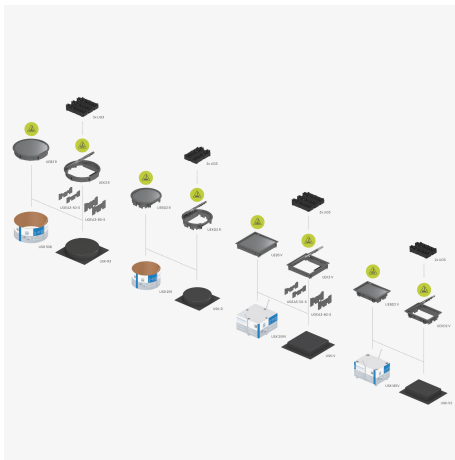
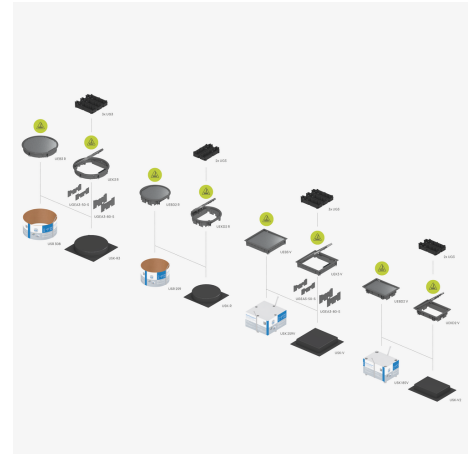
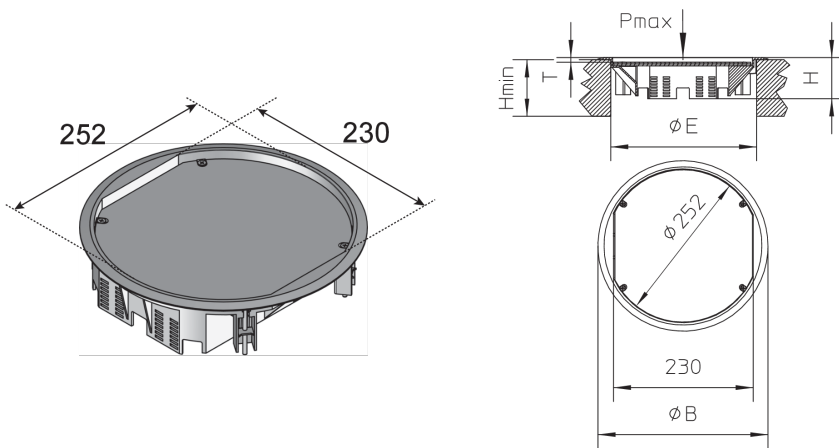

## OPTIONAL ACCESSORIES

UEBD R, UDBS 40-80, UDKSEB



dry maintained



Load requirements according to, DIN EN 50085

