

UBSFW

Floor tray

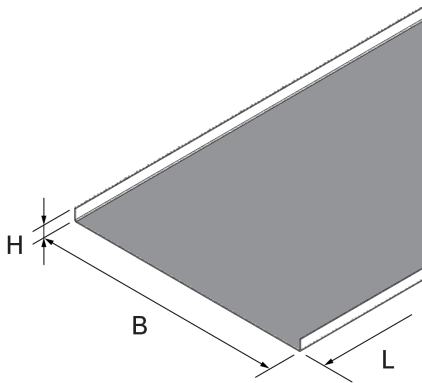

The UBSFW component is a floor tray for the screed-flush duct system UBSF. If electromagnetic compatibility (EMC) is required, UBSFW can be used. It is made of hot-dip galvanised sheet steel and is available in various widths. The component complies with DIN EN 50085 - the European standard for electrical installation duct systems, and is tested and certified by VDE.



steel, continuously hot galvanized/Sendzimir process

Products	H	B	L	t	W
UBSFW 20S	10 mm	200 mm	2000 mm	0,75 mm	2,565 kg
UBSFW 30S	10 mm	300 mm	2000 mm	0,75 mm	3,742 kg
UBSFW 40S	10 mm	400 mm	2000 mm	0,75 mm	4,920 kg
UBSFW 50S	10 mm	500 mm	2000 mm	0,75 mm	6,097 kg
UBSFW 60S	10 mm	600 mm	2000 mm	0,75 mm	7,275 kg

H: height
B: width
L: length
t: material thickness
W: Weight per storage unit

DETAIL AND APPLICATION IMAGES

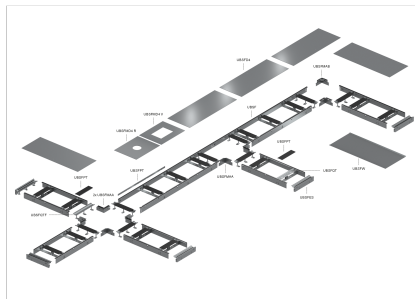
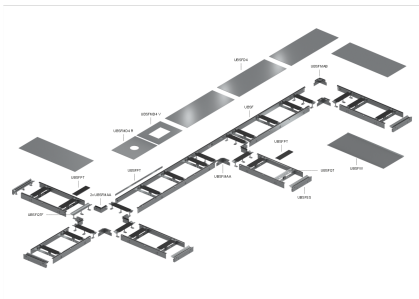

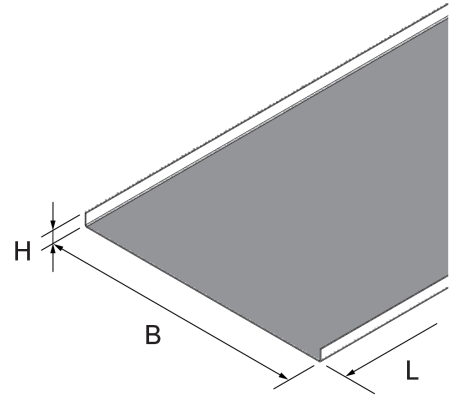

DIN

Load requirements according to, DIN EN 50085

