

UBEBTR

Separating strip

UBEBTR product solutions are separating strips that are used within the screed-flush CHALI duct systems. They are bolted into the brush duct where they safely separate the power cables from the other built-in elements such as data carriers or mounting boxes. These mounting components are made of sendzimir hot-dip galvanised sheet steel in accordance with DIN EN 10346. They are 244 mm long, 23 mm wide and 70 mm high.

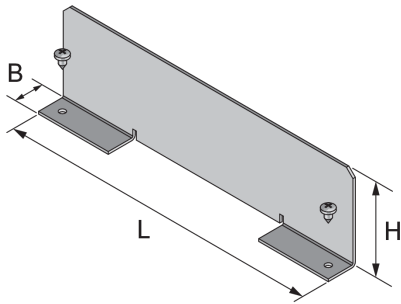

Products	H	B	L	weight
UBEBTR 85-2000S	70 mm	30 mm	2000 mm	2,885 kg
UBEBTR 85S	70 mm	23 mm	244 mm	0,303 kg
incl.:				
2 × BLS 4.8X9.5				

H: height
B: width
L: length

DETAIL AND APPLICATION IMAGES

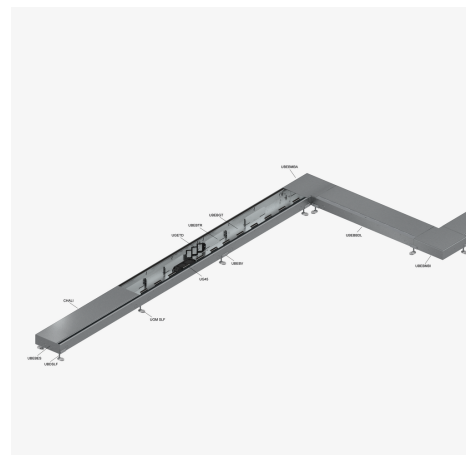
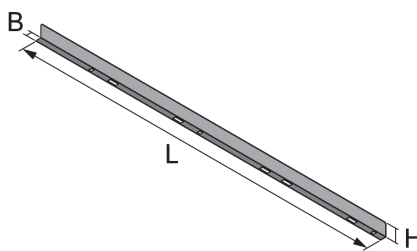
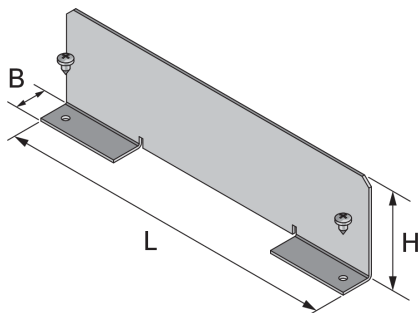

Page 1



PRODUCT INFORMATION



DIN

Load requirements according to, DIN EN 50085

