

UBEBGT

Device carrier fixture

UBEBGT product solutions are elements for holding mounting boxes and data carriers within the screed-flush CHALI duct systems, which are bolted into the brush duct. These mounting components are made of sendzimir hot-dip galvanised sheet steel in accordance with DIN EN 10346. They are 244 mm long, 45 mm wide and 63 mm high. They have VDE/TÜV approval according to DIN EN 50085.

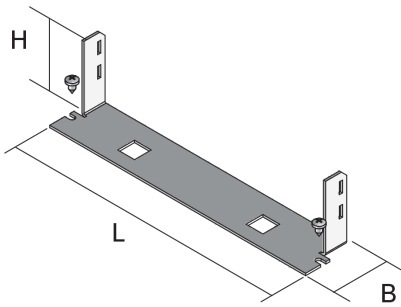

Products	H	B	L	weight
UBEBGT S	63 mm	45 mm	244 mm	0,198 kg
incl.:				
2 x BLS 4.8X9.5				

H: height
B: width
L: length

DETAIL AND APPLICATION IMAGES

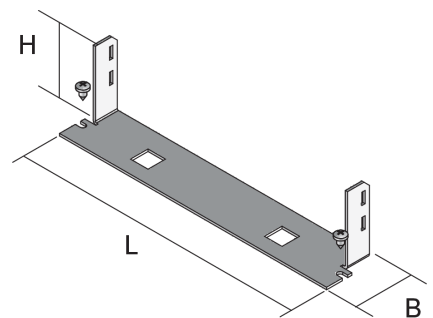
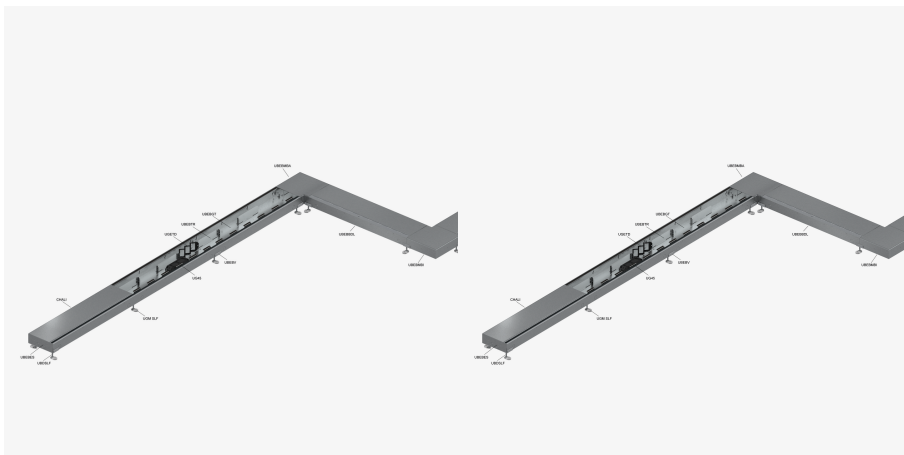

OPTIONAL ACCESSORIES

CHALI

DIN

Load requirements according to, DIN EN 50085

