

## STU 50

Vertical ladder, isosceles U profile

STU 50 vertical ladders consist of perforated side rails with U profiles and rungs made of 40x22 mm profile rails. They are designed for a maximum load of up to 2.00 kN, are 210 to 800 mm wide and are available in standard lengths of 3000 and 6000 mm. We provide components in various materials and surface finishes to ensure that the corrosion requirements are met for all sorts of applications.

steel, continuously hot galvanized/Sendzimir process

Products	H	B	L	P <sub>max</sub>	W
STU 50-02-3S	50 mm	200 mm	3000 mm	2,00 kN	9,750 kg
STU 50-03-3S	50 mm	300 mm	3000 mm	2,00 kN	10,350 kg
STU 50-04-3S	50 mm	400 mm	3000 mm	2,00 kN	10,900 kg
STU 50-05-3S	50 mm	500 mm	3000 mm	2,00 kN	11,500 kg
STU 50-06-3S	50 mm	600 mm	3000 mm	2,00 kN	12,050 kg
STU 50-07-3S	50 mm	700 mm	3000 mm	2,00 kN	12,650 kg
STU 50-08-3S	50 mm	800 mm	3000 mm	2,00 kN	13,250 kg
STU 50-02S	50 mm	200 mm	6000 mm	2,00 kN	19,500 kg
STU 50-03S	50 mm	300 mm	6000 mm	2,00 kN	20,700 kg
STU 50-04S	50 mm	400 mm	6000 mm	2,00 kN	21,800 kg
STU 50-05S	50 mm	500 mm	6000 mm	2,00 kN	23,000 kg
STU 50-06S	50 mm	600 mm	6000 mm	2,00 kN	24,100 kg
STU 50-07S	50 mm	700 mm	6000 mm	2,00 kN	25,300 kg
STU 50-08S	50 mm	800 mm	6000 mm	2,00 kN	26,500 kg

steel, batch/hot-dip galvanized

Products	H	B	L	P <sub>max</sub>	W
STU 50-02-3F	50 mm	200 mm	3000 mm	2,00 kN	10,500 kg
STU 50-03-3F	50 mm	300 mm	3000 mm	2,00 kN	11,050 kg



PohlCon GmbH  
 Nobelstraße 51 | 12057 Berlin  
 Telefon: +49 30 68283-04 | Fax: +49 30 68283-383 | contact@pohlcon.com



# PRODUCT INFORMATION

Products	H	B	L	$P_{max}$	W
STU 50-04-3F	50 mm	400 mm	3000 mm	2,00 kN	11,650 kg
STU 50-05-3F	50 mm	500 mm	3000 mm	2,00 kN	12,300 kg
STU 50-06-3F	50 mm	600 mm	3000 mm	2,00 kN	12,900 kg
STU 50-07-3F	50 mm	700 mm	3000 mm	2,00 kN	13,550 kg
STU 50-08-3F	50 mm	800 mm	3000 mm	2,00 kN	14,150 kg
STU 50-02F	50 mm	200 mm	6000 mm	2,00 kN	21,000 kg
STU 50-03F	50 mm	300 mm	6000 mm	2,00 kN	22,100 kg
STU 50-04F	50 mm	400 mm	6000 mm	2,00 kN	23,300 kg
STU 50-05F	50 mm	500 mm	6000 mm	2,00 kN	24,600 kg
STU 50-06F	50 mm	600 mm	6000 mm	2,00 kN	25,800 kg
STU 50-07F	50 mm	700 mm	6000 mm	2,00 kN	27,100 kg
STU 50-08F	50 mm	800 mm	6000 mm	2,00 kN	28,300 kg

**H:** height  
**B:** width  
**L:** length  
 **$P_{max}$ :** maximum load  
**W:** Weight per storage unit

## DETAIL AND APPLICATION IMAGES

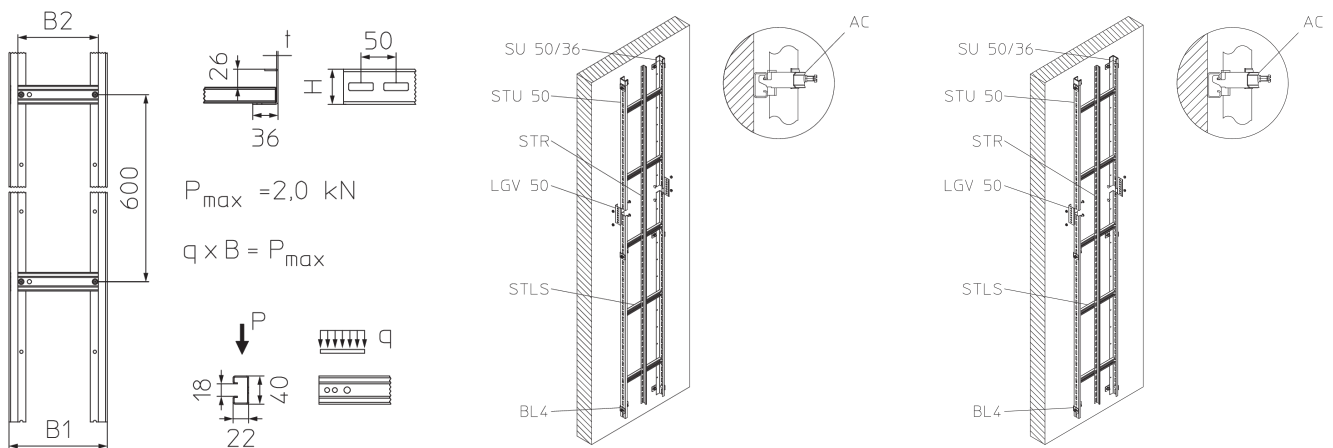

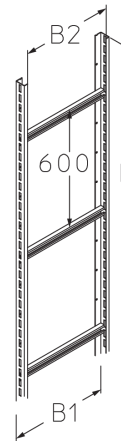
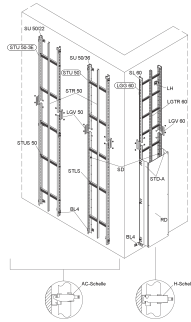
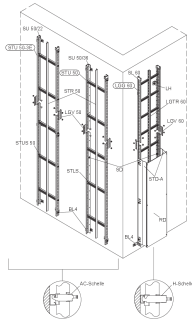

## OPTIONAL ACCESSORIES

AC, BGUQ 50, BL 4, KZF, KZS, LGV 50, LH, RD, STD-A, STLS, STR 110, STR 50, SU 50/36

