

SRS-W

Mounting clamp

The double fixing clamp SRS-W can be used to attach e.g. lights to the protective tube. It can also be used to attach the protective tube itself to masonry, for example. The mounting clamp is available with diameters of 30 or 60 mm. We provide components in various materials and surface finishes to ensure that various corrosion protection requirements for different areas of application are met.

steel, batch/hot-dip galvanized

Products	D	t	weight
SRS-W 30F	31 mm	4,00 mm	0,100 kg
SRS-W 60F	61 mm	4,00 mm	0,320 kg

Stainless steel, according to ASTM 304 / BS 304 S 3

Products	D	t	weight
SRS-W 30E	31 mm	4,00 mm	0,090 kg
SRS-W 60E	61 mm	4,00 mm	0,310 kg

D: diameter

t: material thickness

DETAIL AND APPLICATION IMAGES



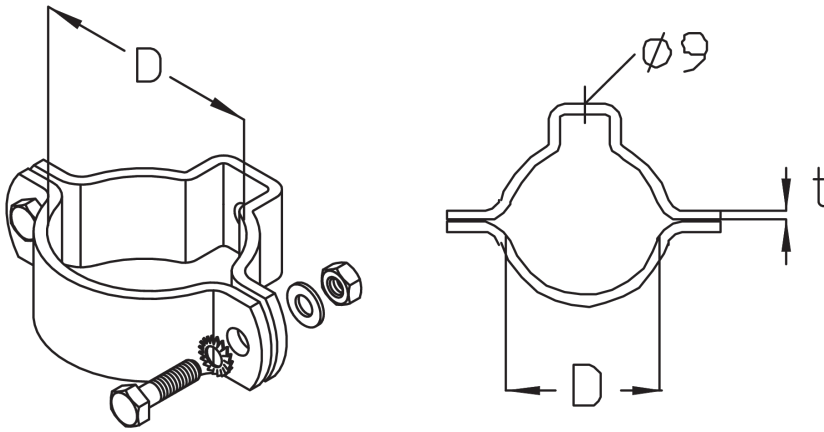

OPTIONAL ACCESSORIES

SR, SRL, SRB 45, SRB 90

