

SRS-B

Pipe bracket clamp

The protective tube is attached to the SRFW base bracket using pipe bracket clamp SRS-B. It is available in diameters of 30 or 60 mm. We provide components in various materials and surface finishes to ensure that various corrosion protection requirements for different areas of application are met.

steel, batch/hot-dip galvanized

Products	D	t	weight
SRS-B 60-10F	61 mm	10,00 mm	0,060 kg

Stainless steel, according to ASTM 304 / BS 304 S 3

Products	D	t	weight
SRS-B 30-6E	31 mm	6,00 mm	0,050 kg
SRS-B 60-8E	61 mm	8,00 mm	0,160 kg

D: diameter

t: material thickness

DETAIL AND APPLICATION IMAGES



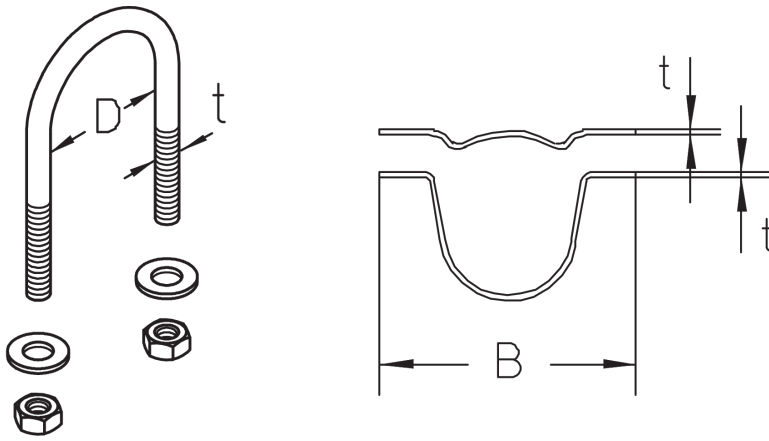

OPTIONAL ACCESSORIES

SR, SRL, SRB 45, SRB 90

