

SRHB

Protective tube holder

The rigid protective tube holder SRHB is used to attach the protective tube system to the corresponding cable tray. It is available in diameters of 30 or 60 mm. We provide components in various materials and surface finishes to ensure that various corrosion protection requirements for different areas of application are met.

steel, batch/hot-dip galvanized

Products	B	D	t	weight
SRHB 30F	6 mm	31 mm	6,00 mm	0,520 kg
SRHB 60F	10 mm	61 mm	10,00 mm	0,620 kg

Stainless steel, according to ASTM 304 / BS 304 S 3

Products	B	D	t	weight
SRHB 30E	6 mm	31 mm	6,00 mm	0,520 kg
SRHB 60E	10 mm	61 mm	8,00 mm	0,620 kg

B: width
D: diameter
t: material thickness

DETAIL AND APPLICATION IMAGES



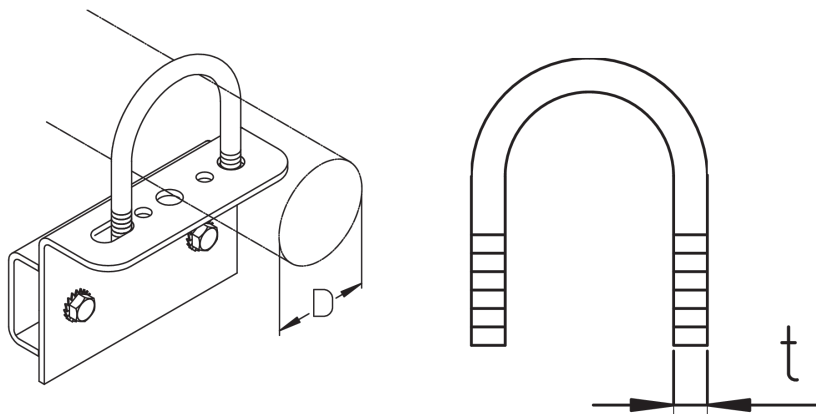

OPTIONAL ACCESSORIES

SR, SRL, SRB 45, SRB 90

