

## SKS A

Clamping claw, heavy, A/KHA 21/41/42/82

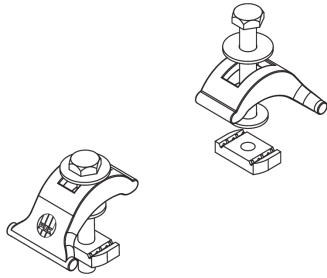

The beam clamp set SKS A can be combined with mounting channels A 41 or KHA 21, 41, 42 and 82. It is used to attach bracket supports on steel beams. The set can be loaded up to 20 kN. The clamping range extends from 10 - 30 mm. We provide components in various materials and surface finishes to ensure that various corrosion protection requirements for different areas of application are met.

steel, batch/hot-dip galvanized

Products	k	P <sub>max</sub>	M	W
SKS AF	10 - 30 mm	20,00 kN	50 Nm	0,555 kg
incl.:				
2 × UVS M10X24, 2 × SES 10X75F, 2 × US 10X30F, 2 × AM22 M10F				

Stainless steel, according to ASTM 316 Ti / AISI 316 L, BS 320S17 / BS 316S11

Products	k	P <sub>max</sub>	M	W
SKS AE4	10 - 30 mm	20,00 kN	50 Nm	0,552 kg
incl.:				
2 × SES 10X75E4, 2 × US 10X30E4, 2 × UVS M10X24, 2 × AM22 M10E4				

**k:** clamping range  
**P<sub>max</sub>:** maximum load  
**M:** torque  
**W:** Weight per storage unit

## DETAIL AND APPLICATION IMAGES



# PRODUCT INFORMATION

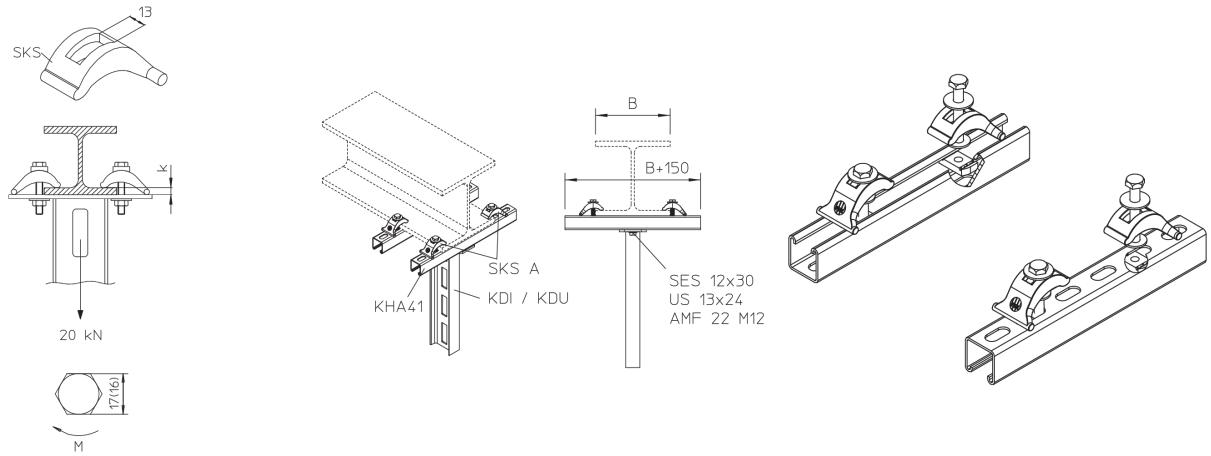

## OPTIONAL ACCESSORIES

A 41, KHA 21, KHA 41, KHA 42, KHA 82

