

SKLL-R

Clamping claw, light with cable tray attachment

The lightweight clamping claw SKLL-R is used to fasten cable trays to steel beams.

steel, batch/hot-dip galvanized

Products	B	L	k	W
SKLL-R F	30 mm	60 mm	5 - 25 mm	0,080 kg
incl.:				
1 x FRS 6X50E, 1 x SEM 6E, 1 x US 6X18E				

B: width
L: length
k: clamping range
W: Weight per storage unit

DETAIL AND APPLICATION IMAGES

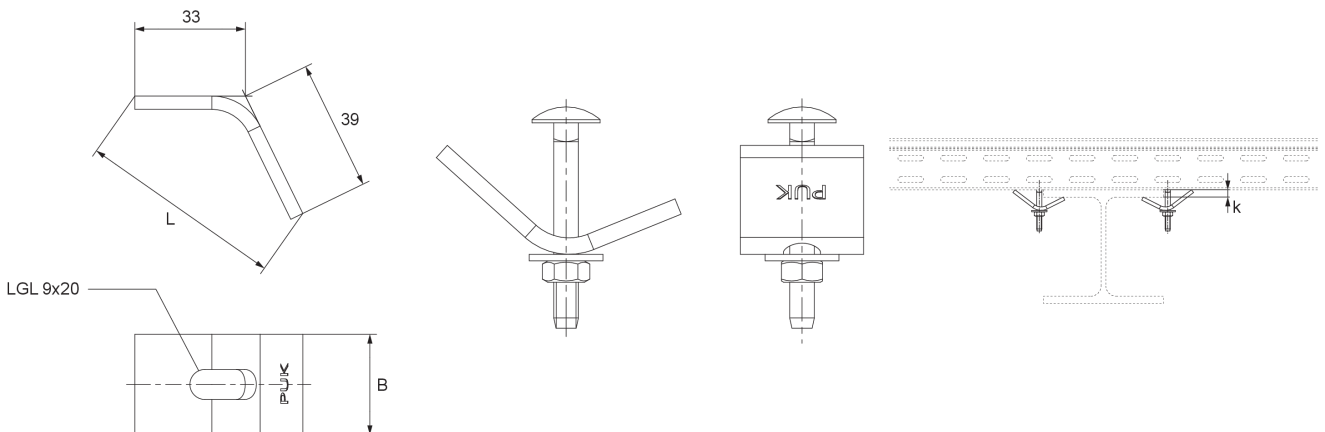

PRODUCT INFORMATION

