

## SK Clamping claw

The SK clamping claw is used to mount the AN beam bracket on angle profiles. The clamping claw is made of hot-dip galvanized steel.

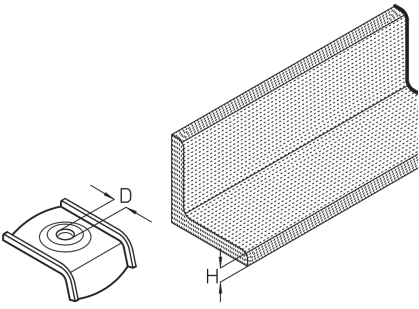

steel, batch/hot-dip galvanized

Products	H	W
SK 4 M8	4 mm	0,035 kg
SK 6 M8	6 mm	0,037 kg
SK 8 M8	8 mm	0,040 kg
SK 10 M8	10 mm	0,041 kg
SK 12 M8	12 mm	0,044 kg

**H:** height

**W:** Weight per storage unit

## DETAIL AND APPLICATION IMAGES



# PRODUCT INFORMATION

---

