

SH QS

Multiple cable holder, metal

The multiple cable holder SH QS is used for flexible and cost-effective routing of installation cables or smaller cable bundles on walls or ceilings. It is 66 or 92 mm high and designed for a maximum load of up to 1.50 or 3 kg/m. The multiple cable holder is made of sendzimir hot-dip galvanized steel making it suitable for use in E30-E90 circuit integrity systems. Installation must be carried out using fastening elements that are approved for fire protection applications.



steel, continuously hot galvanized/Sendzimir process

Products	H	B	L	cables	W
SH 15Q S	66 mm	45 mm	31 mm	15	0,031 kg
SH 30Q S	92 mm	63 mm	34 mm	30	0,072 kg

H: height

B: width

L: length

cables: max. number of cables

W: Weight per storage unit

DETAIL AND APPLICATION IMAGES

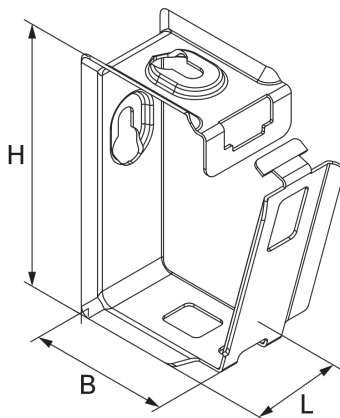

OPTIONAL ACCESSORIES

SD, SAZ

