

RTRV 110

Cable tray separating strip, variable, height = 100 mm

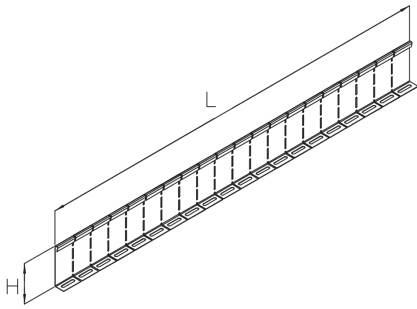

Cables and wires with different functions or voltages can be routed separately from one another using the variable cable tray separating strip RTRV 110. The separating strip is separated into segments. This makes it flexible and ideal for being installed in formed parts. Mounting bolts are included. The cable tray separating strip RTRV 110 is 100 mm high and 1000 mm long. We provide components in various materials and surface finishes to ensure that the corrosion requirements are met for all sorts of applications.

steel, continuously hot galvanized/Sendzimir process

Products	H	L	t	weight
RTRV 110S	100 mm	1000 mm	0,75 mm	0,782 kg
incl.:				
3 × FRSV 6X12, 3 × SEMS 6				

Stainless steel, according to ASTM 304 / BS 304 S 3

Products	H	L	t	weight
RTRV 110E	100 mm	1000 mm	0,80 mm	0,841 kg
incl.:				
3 × FRSV 6X12E, 3 × SEMS 6E				

Stainless steel, according to ASTM 316 Ti / AISI 316 L, BS 320S17 / BS 316S11

Products	H	L	t	weight
RTRV 110E4	100 mm	1000 mm	0,80 mm	0,855 kg
incl.:				
3 × FRSV 6X12E4, 3 × SEM 6E4, 3 × US 6X12E4				



PRODUCT INFORMATION

H: height
L: length
t: material thickness

DETAIL AND APPLICATION IMAGES

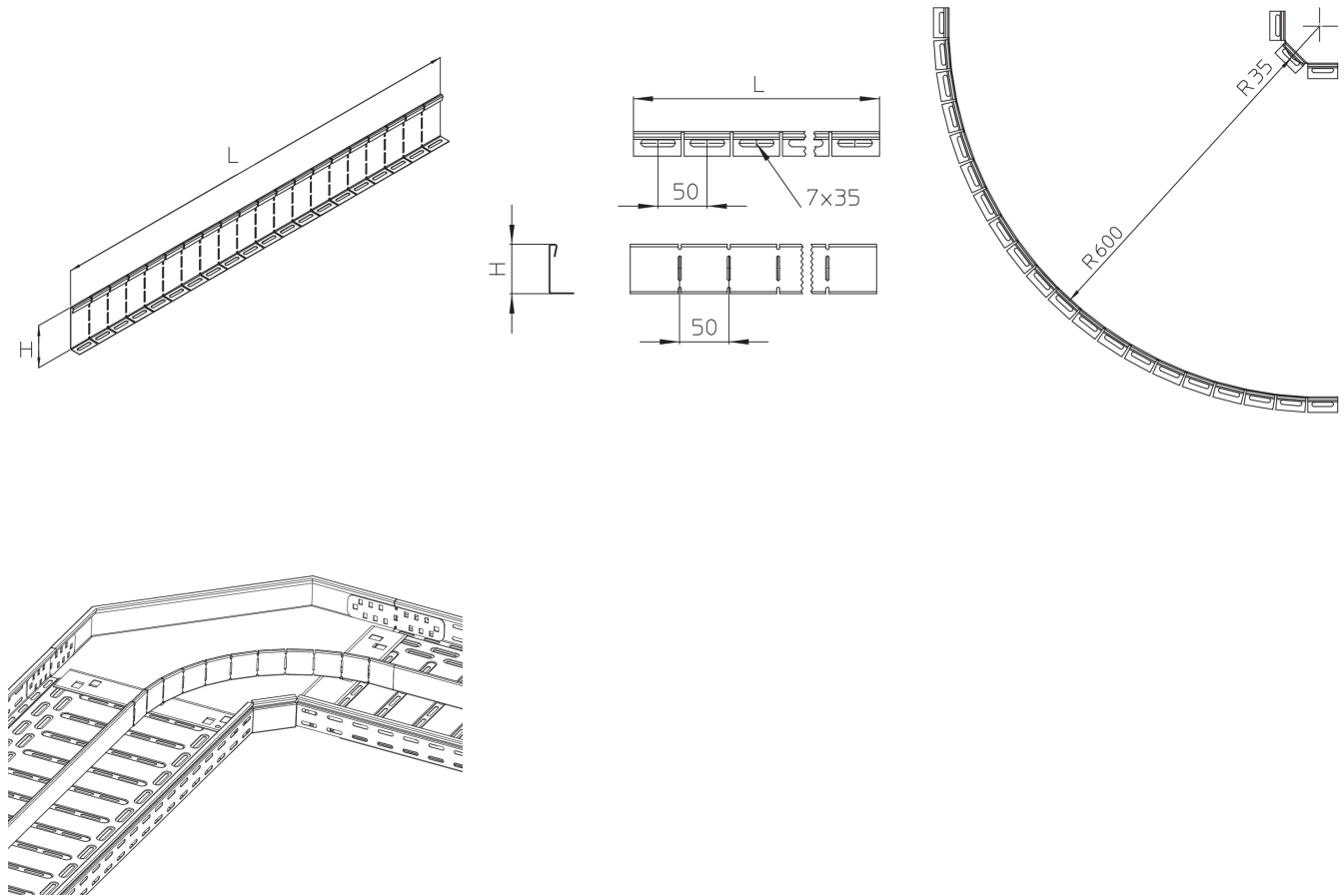

OPTIONAL ACCESSORIES

KLF

