

## RTR 110

Cable tray separating strip, height = 100 mm

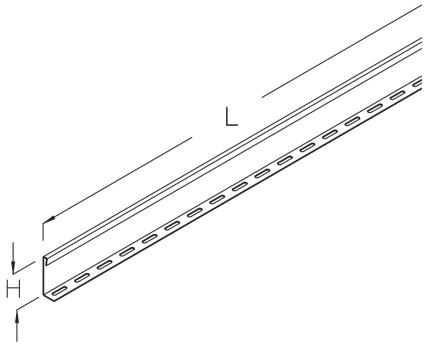

Cables and lines with different functions or voltages can be routed separately from one another in the same cable tray using the cable tray separating strip RTR 110. The separating strip is bolted to the cable tray three times or fastened with KLF approx. 100 mm away from both ends of the separating strip and in the middle. The cable tray separating strip is 100 mm high and 3000 mm long. We provide components in various materials and surface finishes to ensure that the corrosion requirements are met for all sorts of applications.

steel, continuously hot galvanized/Sendzimir process

Products	H	L	W
RTR 110S	100 mm	3000 mm	2,411 kg
incl.:			
3 × KLR			

steel, batch/hot-dip galvanized

Products	H	L	W
RTR 110F	100 mm	3000 mm	2,584 kg
incl.:			
3 × KLR E			

Stainless steel, according to ASTM 304 / BS 304 S 3

Products	H	L	W
RTR 110E	100 mm	3000 mm	3,231 kg
incl.:			
3 × KLR E			



# PRODUCT INFORMATION

---

**H:** height  
**L:** length  
**W:** Weight per storage unit

## DETAIL AND APPLICATION IMAGES

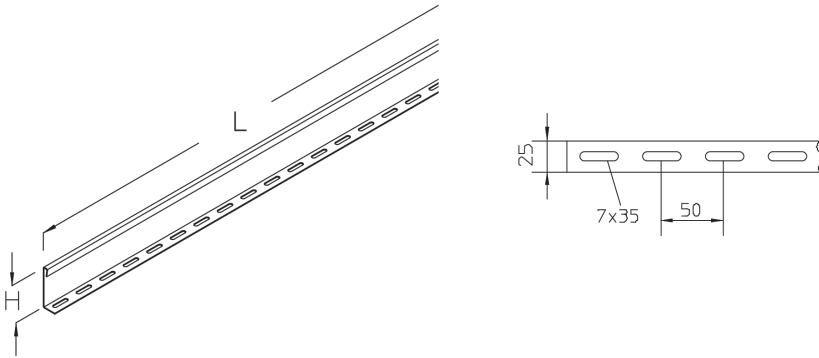

## OPTIONAL ACCESSORIES

KLF

