

## RITR 60

Installation cable tray separating strip, height = 58 mm

Cables and lines with different functions or voltages can be routed separately from one another in the same installation cable tray using the installation cable tray separating strip RITR 60. The separating strip is bolted to the cable tray three times or fastened with KLF approx. 100 mm away from both ends of the separating strip and in the middle. The installation cable tray separating strip RITR 60 is 58 mm high and 3000 mm long and is made of sendzimir hot-dip galvanised steel.

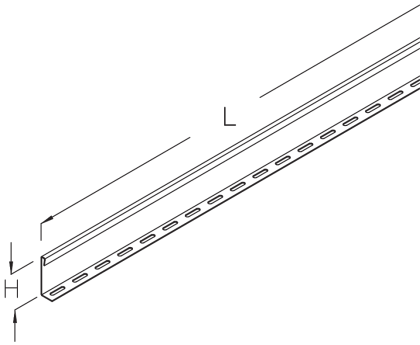

steel, continuously hot galvanized/Sendzimir process

Products	H	L	weight
RITR 60S	58 mm	3000 mm	3,321 kg
incl.:			
3 x KLR			

H: height  
L: length

## DETAIL AND APPLICATION IMAGES

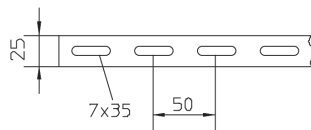
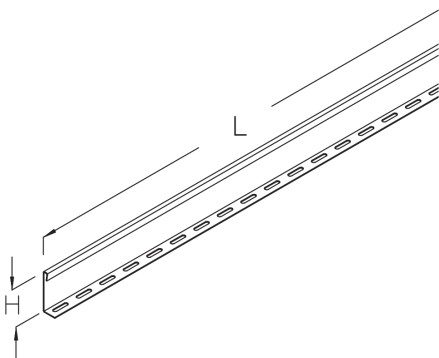



PohlCon GmbH  
Nobelstraße 51 | 12057 Berlin  
Telefon: +49 30 68283-04 | Fax: +49 30 68283-383 | [contact@pohlcon.com](mailto:contact@pohlcon.com)

