

# PRODUCT INFORMATION

---

## RGW

### Reducing thread

The reducing thread RGW is used to bolt W cable clamps to MKD. We provide components in various materials and surface finishes to ensure that various corrosion protection requirements for different areas of application are met.

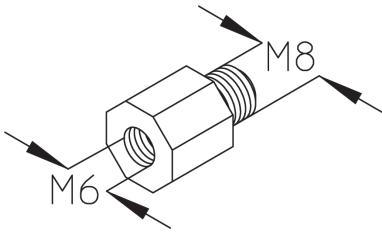

steel, galvanic zinc plated

---

Products	weight
RGW 8/6	0,013 kg

---

Stainless steel, according to ASTM 304 / BS 304 S 3

---

Products	weight
RGW 8/6E	0,013 kg

---

## DETAIL AND APPLICATION IMAGES



# PRODUCT INFORMATION

---

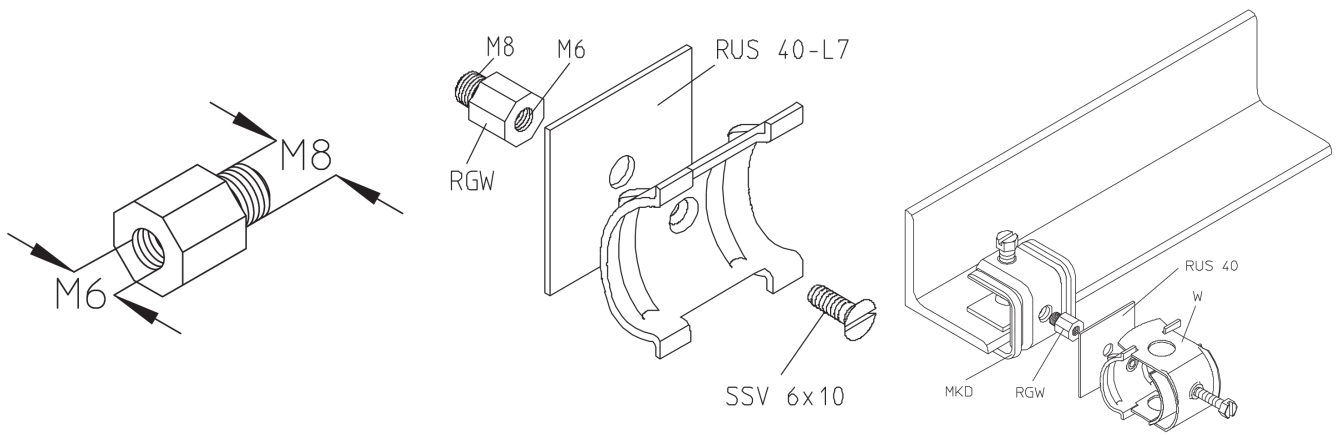

## OPTIONAL ACCESSORIES

MKD

