

## RGS 60

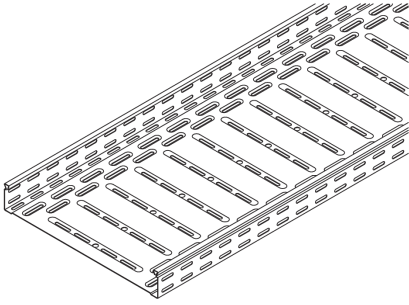

steel, continuously hot galvanized/Senzimir process

Products	H	B	L	t	A	Q <sub>SK</sub>	weight
RGS 60-10S	60 mm	100 mm	3000 mm	1,50 mm	57 cm <sup>2</sup>	0,09 kN/m	8,333 kg
RGS 60-20S	60 mm	200 mm	3000 mm	1,50 mm	117 cm <sup>2</sup>	0,18 kN/m	11,332 kg
RGS 60-30S	60 mm	300 mm	3000 mm	1,50 mm	177 cm <sup>2</sup>	0,27 kN/m	14,640 kg
RGS 60-40S	60 mm	400 mm	3000 mm	1,50 mm	237 cm <sup>2</sup>	0,36 kN/m	17,948 kg
RGS 60-50S	60 mm	500 mm	3000 mm	1,50 mm	297 cm <sup>2</sup>	0,45 kN/m	21,257 kg
RGS 60-60S	60 mm	600 mm	3000 mm	1,50 mm	357 cm <sup>2</sup>	0,54 kN/m	24,565 kg

**H:** height

**B:** width

**L:** length

**t:** material thickness

**A:** cross section area

**Q<sub>SK</sub>:** distributed load control cable

## DETAIL AND APPLICATION IMAGES



# PRODUCT INFORMATION

---

