

## RGS 60

Cable tray, perforated, heavy, height = 60 mm, maintenance of function

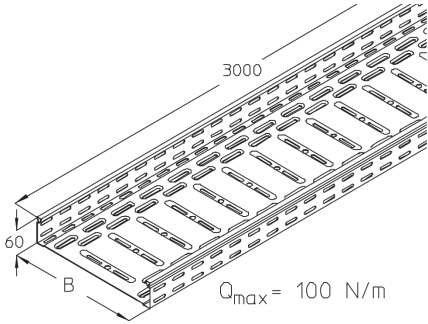

steel, continuously hot galvanized/Sendzimir process

Products	H	B	L	t	A	$Q_{SK}$	W
RGS 60-10S	60 mm	100 mm	3000 mm	1,50 mm	57 cm <sup>2</sup>	0,09 kN/m	8,333 kg
RGS 60-20S	60 mm	200 mm	3000 mm	1,50 mm	117 cm <sup>2</sup>	0,18 kN/m	11,332 kg
RGS 60-30S	60 mm	300 mm	3000 mm	1,50 mm	177 cm <sup>2</sup>	0,27 kN/m	14,640 kg

steel, batch/hot-dip galvanized

Products	H	B	L	t	A	$Q_{SK}$	W
RGS 60-10F	60 mm	100 mm	3000 mm	1,50 mm	57 cm <sup>2</sup>	0,09 kN/m	8,888 kg
RGS 60-20F	60 mm	200 mm	3000 mm	1,50 mm	117 cm <sup>2</sup>	0,18 kN/m	12,087 kg
RGS 60-30F	60 mm	300 mm	3000 mm	1,50 mm	177 cm <sup>2</sup>	0,27 kN/m	15,616 kg

**H:** height

**B:** width

**L:** length

**t:** material thickness

**A:** cross section area

**$Q_{SK}$ :** distributed load control cable

**W:** Weight per storage unit



# PRODUCT INFORMATION

---

## DETAIL AND APPLICATION IMAGES

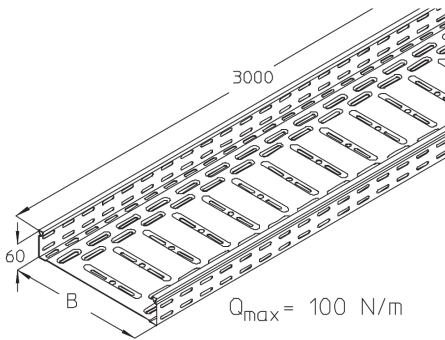

## OPTIONAL ACCESSORIES

RB-BS 60, RB-BS45 60, RAA-BS 60, RGV-BS 60, VB-BS

