

RGL 60

Cable tray, perforated, permeable to extinguishing water, height = 60 mm

The perforated cable trays permeable to extinguishing water RGL 60 have sides 60 mm high and are available in widths from 200 to 600 mm. The standard length is 3000 mm. We provide components in various materials and surface finishes to ensure that the corrosion requirements are met for all sorts of applications.



steel, continuously hot galvanized/Sendzimir process

Products	H	B	L	t	A	Q_{SK}	weight
RGL 60-20S	60 mm	200 mm	3000 mm	0,75 mm	117 cm ²	0,18 kN/m	5,118 kg
RGL 60-30S	60 mm	300 mm	3000 mm	0,75 mm	177 cm ²	0,27 kN/m	6,237 kg
RGL 60-40S	60 mm	400 mm	3000 mm	0,88 mm	237 cm ²	0,36 kN/m	8,610 kg
RGL 60-50S	60 mm	500 mm	3000 mm	1,00 mm	297 cm ²	0,45 kN/m	11,253 kg
RGL 60-60S	60 mm	600 mm	3000 mm	1,00 mm	357 cm ²	0,54 kN/m	12,745 kg

steel, batch/hot-dip galvanized

Products	H	B	L	t	A	Q_{SK}	weight
RGL 60-20F	60 mm	200 mm	3000 mm	0,75 mm	117 cm ²	0,18 kN/m	5,738 kg
RGL 60-30F	60 mm	300 mm	3000 mm	0,75 mm	177 cm ²	0,27 kN/m	6,992 kg
RGL 60-40F	60 mm	400 mm	3000 mm	0,88 mm	237 cm ²	0,36 kN/m	9,499 kg
RGL 60-50F	60 mm	500 mm	3000 mm	1,00 mm	297 cm ²	0,45 kN/m	12,378 kg
RGL 60-60F	60 mm	600 mm	3000 mm	1,00 mm	357 cm ²	0,54 kN/m	14,019 kg

H: height

B: width

L: length

t: material thickness

A: cross section area

Q_{SK} : distributed load control cable



PRODUCT INFORMATION

DETAIL AND APPLICATION IMAGES

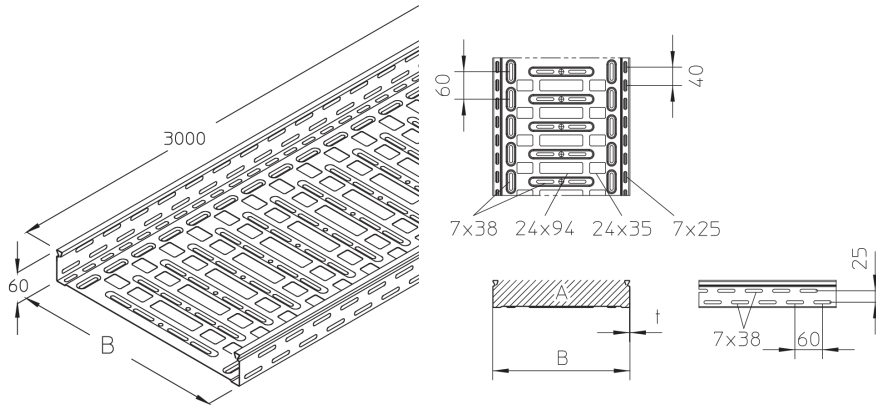

LOAD DIAGRAM

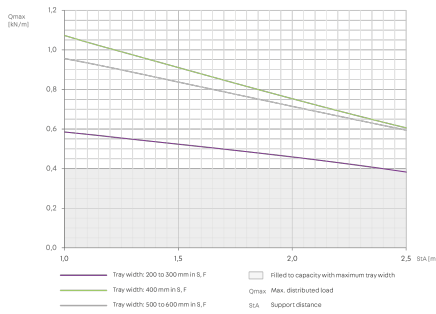

OPTIONAL ACCESSORIES

RD, RDR, RB 60, RB45 60, MA 60, RBV 60, RAE 60, RAA 60, RA 60, RK 60, RVB 60, RR 60, RAB 60, REB, RGV 60, RGVs 60, VB, RTR 60, KSR 35, KSR 94, RKAB

