

RAA 35

Cable tray attachment branch, height = 35 mm

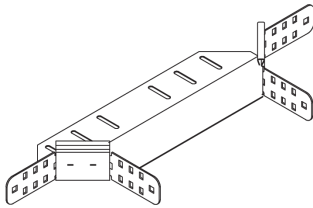

The RAA 35 cable tray attachment branch allows the direction of cable routing to be changed horizontally in the form of a branch. The side rail of the main cable tray is cut out at the point where the connection cable tray will branch off as specified in the installation instructions. The RAA attachment branch is positioned and bolted in place at this point. The VB floor connector and the connection cable tray can then be attached. The RAA 35 cable tray attachment branch is suitable for cable trays with sides 35 mm high. We provide components in various materials and surface finishes to ensure that the corrosion requirements are met for all sorts of applications.

steel, continuously hot galvanized/Senzimir process

Products	H	B	weight
RAA 35-10S	35 mm	100 mm	0,479 kg
incl.:			
2 × KLR			
RAA 35-20S	35 mm	200 mm	0,610 kg
incl.:			
2 × KLR			
RAA 35-30S	35 mm	300 mm	0,743 kg
incl.:			
2 × KLR			

steel, batch/hot-dip galvanized

Products	H	B	weight
RAA 35-10F	35 mm	100 mm	0,515 kg
incl.:			
2 × KLR E			
RAA 35-20F	35 mm	200 mm	0,655 kg
incl.:			
2 × KLR E			
RAA 35-30F	35 mm	300 mm	0,797 kg

Page 1



PRODUCT INFORMATION

Products	H	B	weight
incl: 2 × KLR E			

H: height
B: width

DETAIL AND APPLICATION IMAGES

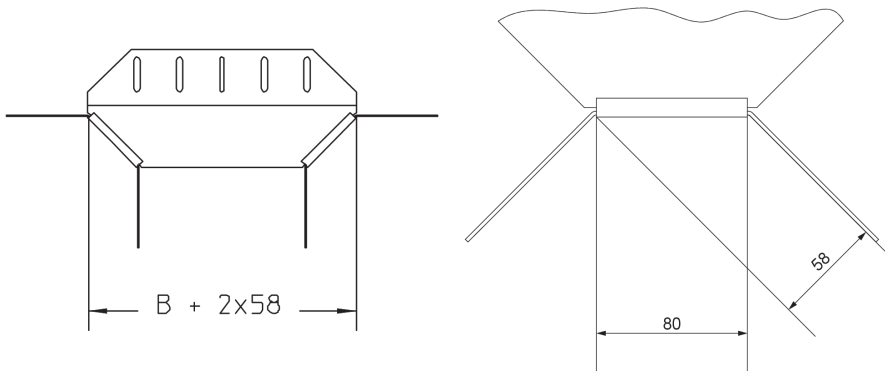

OPTIONAL ACCESSORIES

RAAD, RAADR, VB, RTRV 35

