

## MKD

### Mounting clamp

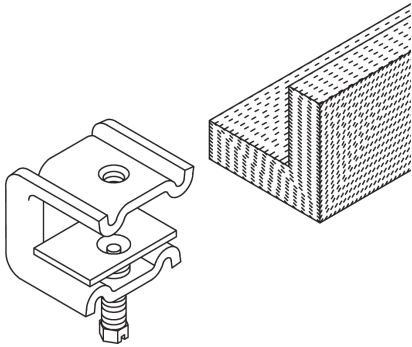

The mounting clamp MKD with riveted pressure plate is used for clamp fastening to steel beams. The MKD-L accessory can be mounted on the mounting clamp itself. This can be used, for example, to attach small mesh cable trays and cable trays protruding out into the room. Furthermore, the W clamp or the HF-EL-clamp can be mounted directly on the MKD. The maximum load is between 1.3 and 1.5 kN. The clamping range extends from 6 to 40 mm. In conjunction with a grub screw that penetrates the coating, the mounting clamp can be included in the equipotential bonding. The article is also available with lock nuts. This prevents the clamp from unintentionally coming loose. Grub screw and lock nuts must be specified separately when ordering.

steel, batch/hot-dip galvanized

Products	ø	B	k	P <sub>max</sub>	M	weight
MKD 21	8 mm	44 mm	6 - 21 mm	1,50 kN	4 Nm	0,190 kg
MKD 21 M6	6 mm	44 mm	6 - 21 mm	1,50 kN	4 Nm	0,180 kg
MKD 21 M10	10 mm	44 mm	6 - 21 mm	1,50 kN	4 Nm	0,173 kg
MKD 40	8 mm	44 mm	20 - 40 mm	1,30 kN	4 Nm	0,204 kg

Stainless steel, according to ASTM 304 / BS 304 S 3

Products	ø	B	k	P <sub>max</sub>	M	weight
MKD 21E	8 mm	44 mm	6 - 21 mm	1,50 kN	4 Nm	0,190 kg
MKD 21E M6	6 mm	44 mm	6 - 21 mm	1,50 kN	4 Nm	0,165 kg
MKD 21E M10	10 mm	44 mm	6 - 21 mm	1,50 kN	4 Nm	0,190 kg
MKD 40E	8 mm	44 mm	20 - 40 mm	1,30 kN	4 Nm	0,193 kg

Stainless steel, according to ASTM 316 Ti / AISI 316 L, BS 320S17 / BS 316S11

Products	ø	B	k	P <sub>max</sub>	M	weight
MKD 21E4	8 mm	44 mm	6 - 21 mm	1,50 kN	4 Nm	0,190 kg
MKD 40E4	8 mm	44 mm	20 - 40 mm	1,30 kN	4 Nm	0,193 kg

Page 1



# PRODUCT INFORMATION

Ø: thread diameter  
B: width  
k: clamping range  
P<sub>max</sub>: maximum load  
M: torque

## DETAIL AND APPLICATION IMAGES

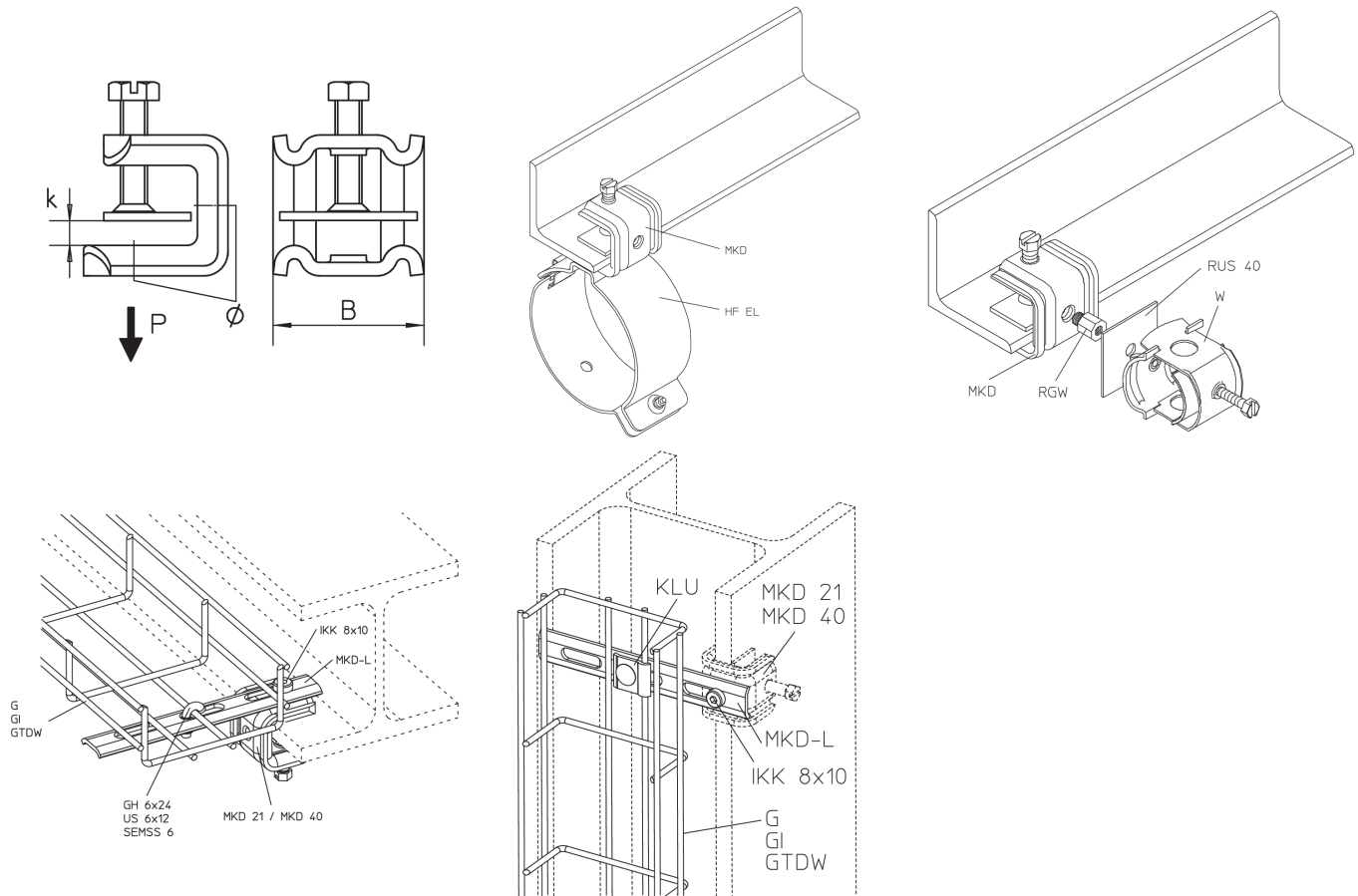

## OPTIONAL ACCESSORIES

MKD-L, RGW

