

LW

Long trough, maintenance of function

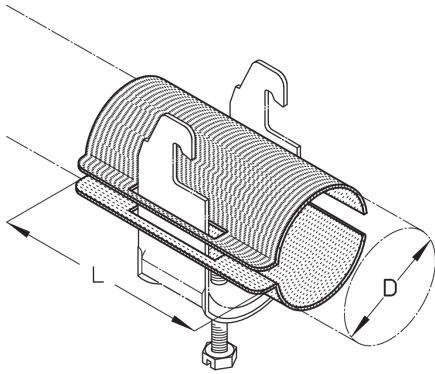

steel, continuously hot galvanized/Sendzimir process

Products	L	D	Cable diameter	W
LW 12	70 mm	9 - 12 mm	12 mm	0,009 kg
LW 16	70 mm	13 - 16 mm	16 mm	0,010 kg
LW 20	70 mm	17 - 20 mm	20 mm	0,012 kg
LW 24	70 mm	21 - 24 mm	24 mm	0,015 kg
LW 28	70 mm	25 - 28 mm	28 mm	0,018 kg
LW 32	70 mm	29 - 32 mm	32 mm	0,022 kg
LW 36	70 mm	33 - 36 mm	36 mm	0,023 kg
LW 40	70 mm	37 - 40 mm	40 mm	0,026 kg
LW 44	70 mm	41 - 44 mm	44 mm	0,031 kg
LW 48	70 mm	45 - 48 mm	48 mm	0,034 kg
LW 52	70 mm	49 - 52 mm	52 mm	0,036 kg
LW 56	70 mm	53 - 56 mm	56 mm	0,039 kg
LW 60	70 mm	57 - 60 mm	60 mm	0,038 kg
LW 64	70 mm	61 - 64 mm	64 mm	0,045 kg
LW 70	70 mm	65 - 70 mm	70 mm	0,048 kg
LW 76	70 mm	71 - 76 mm	76 mm	0,118 kg
LW 82	100 mm	77 - 82 mm	82 mm	0,127 kg
LW 88	100 mm	83 - 88 mm	88 mm	0,137 kg
LW 94	100 mm	89 - 94 mm	94 mm	0,146 kg
LW 100	100 mm	95 - 100 mm	100 mm	0,155 kg
LW 110	100 mm	101 - 110 mm	110 mm	0,171 kg

Page 1



PRODUCT INFORMATION

Products	L	D	Cable diameter	W
LW 120	100 mm	111 - 120 mm	120 mm	0,186 kg

L: length

D: diameter

Cable diameter: Suitable for max. cable diameter

W: Weight per storage unit

DETAIL AND APPLICATION IMAGES

