

KWMS

Wall/strut bracket, medium weight

The wall/strut bracket KWMS is intended for maximum loads of up to 3.8 kN and is ideal for cable ladders up to 600 mm wide. We provide components in various materials and surface finishes to ensure that the corrosion requirements are met for all sorts of applications. The bracket KWMS is also used as a strut bracket in the U support system. F_D/P : factor for calculating the dowel load F_D with the actual bracket load P or the sum of the actual bracket loads. The stated load values only apply if the product is adequately anchored to the force-absorbing substrate or is attached to suspension struts in accordance with the instructions.

steel, galvanic zinc plated

Products	H	B2	L	P_{max}	F_D/P	W
KWMS 010GV	110 mm	120 mm	128 mm	3,80 kN	1,36	0,495 kg
KWMS 020GV	110 mm	220 mm	228 mm	3,80 kN	1,81	0,710 kg
KWMS 030GV	110 mm	320 mm	328 mm	3,80 kN	2,32	0,925 kg
KWMS 040GV	110 mm	420 mm	428 mm	3,80 kN	2,86	1,130 kg
KWMS 050GV	110 mm	520 mm	528 mm	3,80 kN	3,42	1,336 kg
KWMS 060GV	110 mm	620 mm	628 mm	3,80 kN	3,99	1,542 kg

steel, batch/hot-dip galvanized

Products	H	B2	L	P_{max}	F_D/P	W
KWMS 010F	110 mm	120 mm	128 mm	3,80 kN	1,36	0,530 kg
KWMS 020F	110 mm	220 mm	228 mm	3,80 kN	1,81	0,760 kg
KWMS 030F	110 mm	320 mm	328 mm	3,80 kN	2,32	0,990 kg
KWMS 040F	110 mm	420 mm	428 mm	3,80 kN	2,86	1,210 kg
KWMS 050F	110 mm	520 mm	528 mm	3,80 kN	3,42	1,430 kg
KWMS 060F	110 mm	620 mm	628 mm	3,80 kN	3,99	1,650 kg

Stainless steel, according to ASTM 304 / BS 304 S 3



PRODUCT INFORMATION

Products	H	B2	L	P _{max}	F _D /P	W
KWMS 010E	110 mm	120 mm	128 mm	3,80 kN	1,36	0,510 kg
KWMS 020E	110 mm	220 mm	228 mm	3,80 kN	1,81	0,730 kg
KWMS 030E	110 mm	320 mm	328 mm	3,80 kN	2,32	0,940 kg
KWMS 040E	110 mm	420 mm	428 mm	3,80 kN	2,86	1,160 kg
KWMS 050E	110 mm	520 mm	528 mm	3,80 kN	3,42	1,370 kg
KWMS 060E	110 mm	620 mm	628 mm	3,80 kN	3,99	1,580 kg

Stainless steel, according to ASTM 316 Ti / AISI 316 L, BS 320S17 / BS 316S11

Products	H	B2	L	P _{max}	F _D /P	W
KWMS 010E4	110 mm	120 mm	128 mm	3,80 kN	1,36	0,520 kg
KWMS 020E4	110 mm	220 mm	228 mm	3,80 kN	1,81	0,740 kg
KWMS 030E4	110 mm	320 mm	328 mm	3,80 kN	2,32	0,950 kg
KWMS 040E4	110 mm	420 mm	428 mm	3,80 kN	2,86	1,170 kg
KWMS 050E4	110 mm	520 mm	528 mm	3,80 kN	3,42	1,380 kg
KWMS 060E4	110 mm	620 mm	628 mm	3,80 kN	3,99	1,600 kg

H: height

B2: width 2

L: length

P_{max}: maximum load

F_D/P: dowel-to-anchor load

W: Weight per storage unit

DETAIL AND APPLICATION IMAGES



PRODUCT INFORMATION

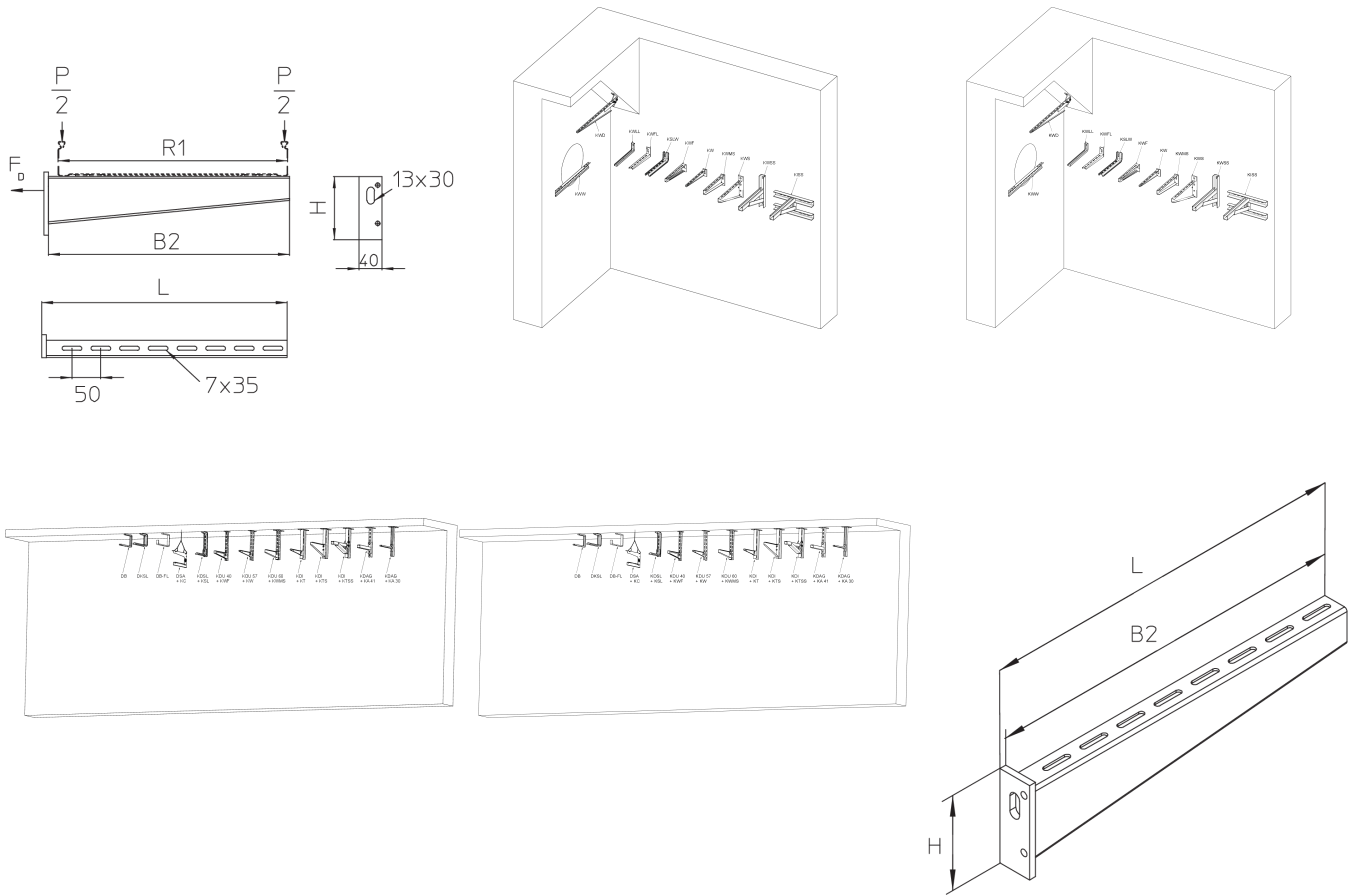

OPTIONAL ACCESSORIES

KDU 57, KHU 57, KDU 60, KHU 60, SD, KLU, KLR, RP

