

KT

Bracket, standard, KDI/KHI

The strut bracket KT is attached to the KDI or KHI bracket holder and is intended for loads up to 2.1 kN. Various surfaces ensure that the corrosion requirements of a wide variety of applications are met.

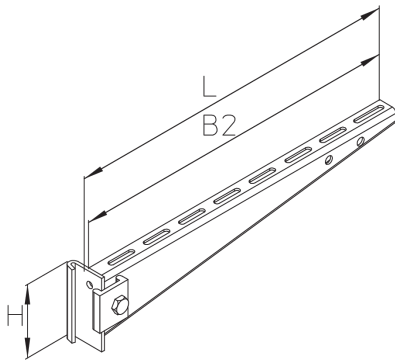

steel, galvanic zinc plated

Products	H	B1	B2	L	P _{max}	weight
KT 010GV	50 mm	100 mm	120 mm	124 mm	2,00 kN	0,242 kg
KT 020GV	70 mm	200 mm	220 mm	224 mm	2,00 kN	0,463 kg
KT 030GV	70 mm	300 mm	320 mm	324 mm	2,00 kN	0,558 kg
KT 040GV	90 mm	400 mm	420 mm	424 mm	2,00 kN	0,895 kg
KT 050GV	110 mm	500 mm	520 mm	524 mm	2,00 kN	1,338 kg
KT 060GV	110 mm	600 mm	620 mm	624 mm	2,10 kN	1,548 kg

steel, batch/hot-dip galvanized

Products	H	B1	B2	L	P _{max}	weight
KT 010F	50 mm	100 mm	120 mm	124 mm	2,00 kN	0,259 kg
KT 020F	70 mm	200 mm	220 mm	224 mm	2,00 kN	0,484 kg
KT 030F	70 mm	300 mm	320 mm	324 mm	2,00 kN	0,594 kg
KT 040F	90 mm	400 mm	420 mm	424 mm	2,00 kN	0,958 kg
KT 050F	110 mm	500 mm	520 mm	524 mm	2,00 kN	1,429 kg
KT 060F	110 mm	600 mm	620 mm	624 mm	2,10 kN	1,654 kg

H: height
B1: width
B2: width

Page 1



PRODUCT INFORMATION

L: length
 P_{max} : maximum load

DETAIL AND APPLICATION IMAGES

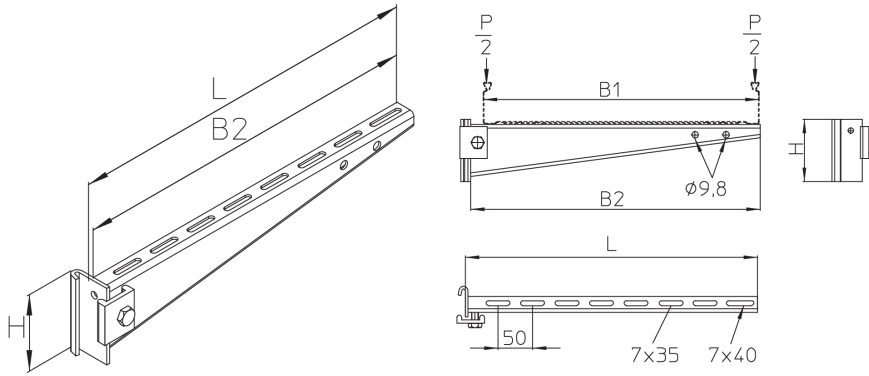

OPTIONAL ACCESSORIES

KLU, KLR

